



wheelblastIT

F O L L O W - A L O N G W H E E L B L A S T E R

Instruction Manual

V 2.0, 8-12-24

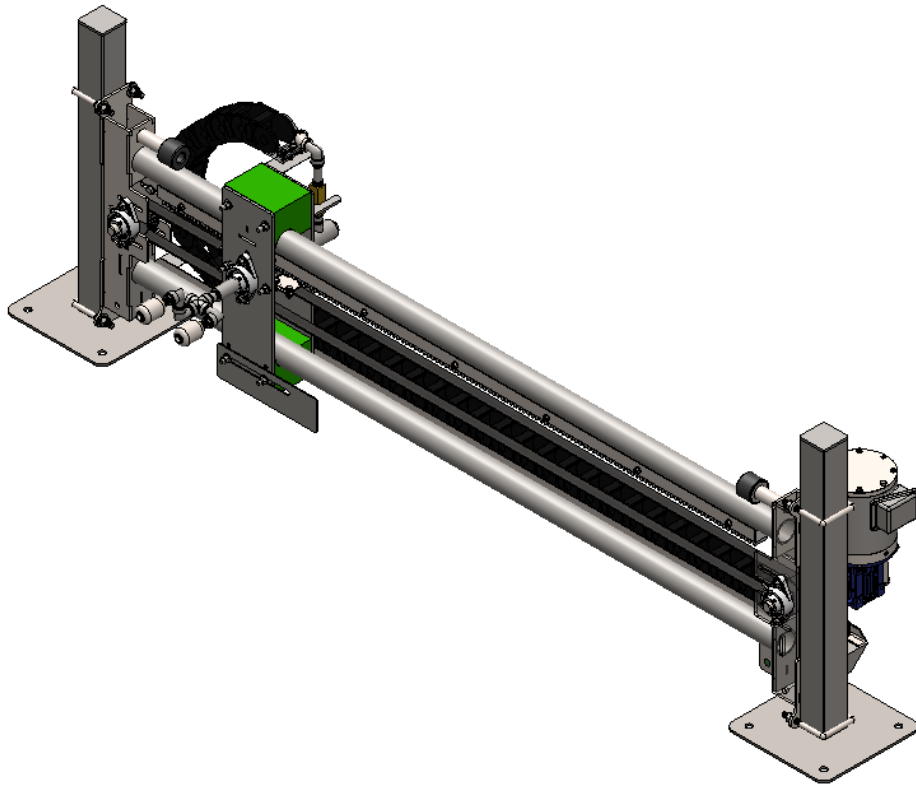

For Further Assistance Please Contact
innovateIT Car Wash Equipment LLC
518-741-4200 option 2
support@innovateITcarwash.com

Table of Contents

- 1. Introduction..... 1**
 - 1.1 Warranty..... 1
 - 1.2 Safety Information..... 1
 - 1.2.1 Notifications & Symbols 2
- 2. System Overview..... 3**
 - 2.1 Features & Functions..... 3
 - 2.2 System Specifications..... 6
- 3. Installation..... 7**
 - 3.1 Installation Preparation 7
 - 3.2 Mechanical Installation..... 7
 - 3.2 Mechanical Installation 7**
 - 3.2.1 Installing Water Lines 9
 - 3.3 Electrical Installation 9
 - 3.3.1 Water Solenoid Setup 14
 - 3.3.2 Remote Connection 15
 - 3.3.3 Setting wheelblastIT Tunnel Controller Function..... 15
- 4. Startup & Operation 16**
 - 4.1 Turning On Power Supply 16
 - 4.2 Conveyor Set Up..... 16
 - 4.3 Starting Trolley Movement 17
 - 4.4 Verifying Motor Rotation..... 18
 - 4.5 Testing the System..... 19
- 5. Service & Maintenance 21**
 - 5.1 Service Schedule 21
- 6. Troubleshooting 22**
- Spare Parts..... 25**
 - 7.1 Recommended Spare Parts..... 25
 - 7.2 Spare Part Replacement..... 25
 - 7.2.1 Replacing Belt..... 25
 - 7.2.2 Replacing Spur Gear & Water Shaft Assembly 26
 - 7.2.3 Replacing Home Proximity Sensor 28
 - 7.2.4 Replacing Slide Block 29
 - 7.2.5 Replacing Belt Clamps..... 30
 - 7.2.6 Replacing Drive Sprocket..... 31
 - 7.2.7 Replacing Gearbox 33
- Appendix 1 - System Identification..... 35**
- Appendix 2 - Parts & Service Notes..... 37**
- Appendix 3 - HMI Screens 42**
- Appendix 4 - Electrical Schematics - 120 VAC 44**
- Appendix 5 - Electrical Schematics - 24 VAC 56**

Introduction

1. Introduction

The manufacturer innovateIT Car Wash Equipment LLC is committed to the continuous improvement of its equipment construction quality and the safe operation of its equipment.

1.1 Warranty

This manual covers the installation, intended use, and maintenance of the wheelblastIT Follow-Along Wheel Blaster. Misuse or improper operation of this device will void the manufacturer's warranty.

The wheelblastIT is covered by a 1-year limited warranty from the date of shipment. This warranty shall be void and of no effect if:

1. Any installation defect that was apparent or ascertainable at the time of installation was completed but was not promptly reported to innovateIT Car Wash Equipment LLC.
2. Damage occurs due to the customer's failure to observe any instructions from innovateIT Car Wash Equipment or an authorized distributor and/or requirements of the manufacturer with respect to the product.
3. The breach results from misuse of the equipment as outlined in the instruction manual.

When purchasing through a distributor, please ask about their warranty coverage on the unit.

1.2 Safety Information

The instructions in this manual provide you with the information necessary to install and operate the wheelblastIT. Before starting installation, the instruction manual should be carefully read and understood. This relates to all wheelblastIT documents from innovateIT Car Wash Equipment.

The basic pre-requisite for safe working is compliance with all the safety and handling instructions stated in this manual. Furthermore, follow all local accident, hazard prevention regulations or general safety regulations when installing and operating the wheelblastIT.

The equipment's operation, maintenance, and troubleshooting must only be carried out by trained personnel. Personnel should be able to interpret a wiring diagram, use a multimeter to read AC and DC power, and apply Lock Out Tag Out (LOTO) safety procedures specific to the equipment.

Eye protection should be worn at all times when operating the wheelblastIT, as the unit includes high pressure water lines.

Electrical installation must adhere to local codes and the National Electrical Code, ANSI/NFPA 70 for electrical wiring. To avoid electrical shock hazards, do not operate this device when controller enclosures are open and energized. Electrical power must be shut off and a lock-out procedure utilized to ensure all electrical power is disabled before performing maintenance to any portion of the system.

Plumbing installation must adhere to a local code and Uniform Plumbing Code (UPC), and plumbing connections and drains must adhere to local standards and facility codes.

Do not remove any Caution, Warning, or any other descriptive labels from the wheelblastIT. Do not operate this device in an explosive environment or in the presence of flammable materials.

Movement or vibrations during shipment may cause connections to loosen. Check all connections before starting up a unit.

This unit's electrical enclosure is intended for installation in ordinary locations, by the National Electrical Code, ANSI/NFPA 70, where the ambient temperature does not exceed 104°F maximum.

innovateIT Car Wash Equipment LLC does not accept liability for accidents or damages due to negligence or disregard for the instructions in this manual. Also, the Company does not accept liability for damages due to improper use of the equipment.

This instruction manual should always be kept in a safe and easily accessible place near the equipment's site of installation and operation, and be available for the operator at the user site at any time.

If the manual is damaged, lost, or misplaced, you should immediately request a new copy from innovateIT Car Wash Equipment LLC.

1.2.1 Notifications & Symbols



DANGER

DANGER indicates a hazardous situation which, if not avoided, will result in death or serious injury.



WARNING

WARNING indicates a hazardous situation which, if not avoided, could result in death or serious injury.



CAUTION

CAUTION indicates a hazardous situation which, if not avoided, could result in minor or moderate injury.



NOTE

NOTE is used to address practices not related to physical injury.

System Overview

2. System Overview

The wheelblastIT is a high-performance, follow-along wheel cleaning system designed specifically for car wash tunnels, featuring electric-powered belt-driven trolleys that slide along five-foot rails. It delivers high-pressure water through rotating nozzles to effectively remove dirt, grime, and brake dust from wheels, ensuring a thorough and efficient wash every time, and providing the benefit of cleaning the wheels of a vehicle as it travels along the conveyor.

2.1 Features & Functions

innovateIT Car Wash Equipment LLC has developed a follow-along wheel blaster to provide high-quality wheel cleaning.

Each wheelblastIT assembly features a trident with 3 zero-degree rotating nozzles. The system operation consists of a series of electronic signals that control the mechanical functions of trolley movement and high-pressure water sprayed through the 3-nozzle assembly on each trolley.

The wheelblastIT is built with robust materials to withstand the rigors of continuous operation in high-volume car washes, while minimizing maintenance and downtime.

The system's PLC controls the forward and reverse movement of the trolleys by adjusting the frequency of the VFD based on pre-calculated distances and the rate of the pulse signal. This allows for precise and consistent movement of the trolleys, ensuring that they travel the correct distance to effectively clean each wheel.

The integrated HMI allows operators to view and edit PLC data easily. This makes it simpler to adjust settings and troubleshoot the system, enhancing overall usability and reducing downtime.

Each assembly also includes a 'Home Proximity Sensor', which ensures the trolleys return to their home positions accurately, facilitating smooth and precise operations.

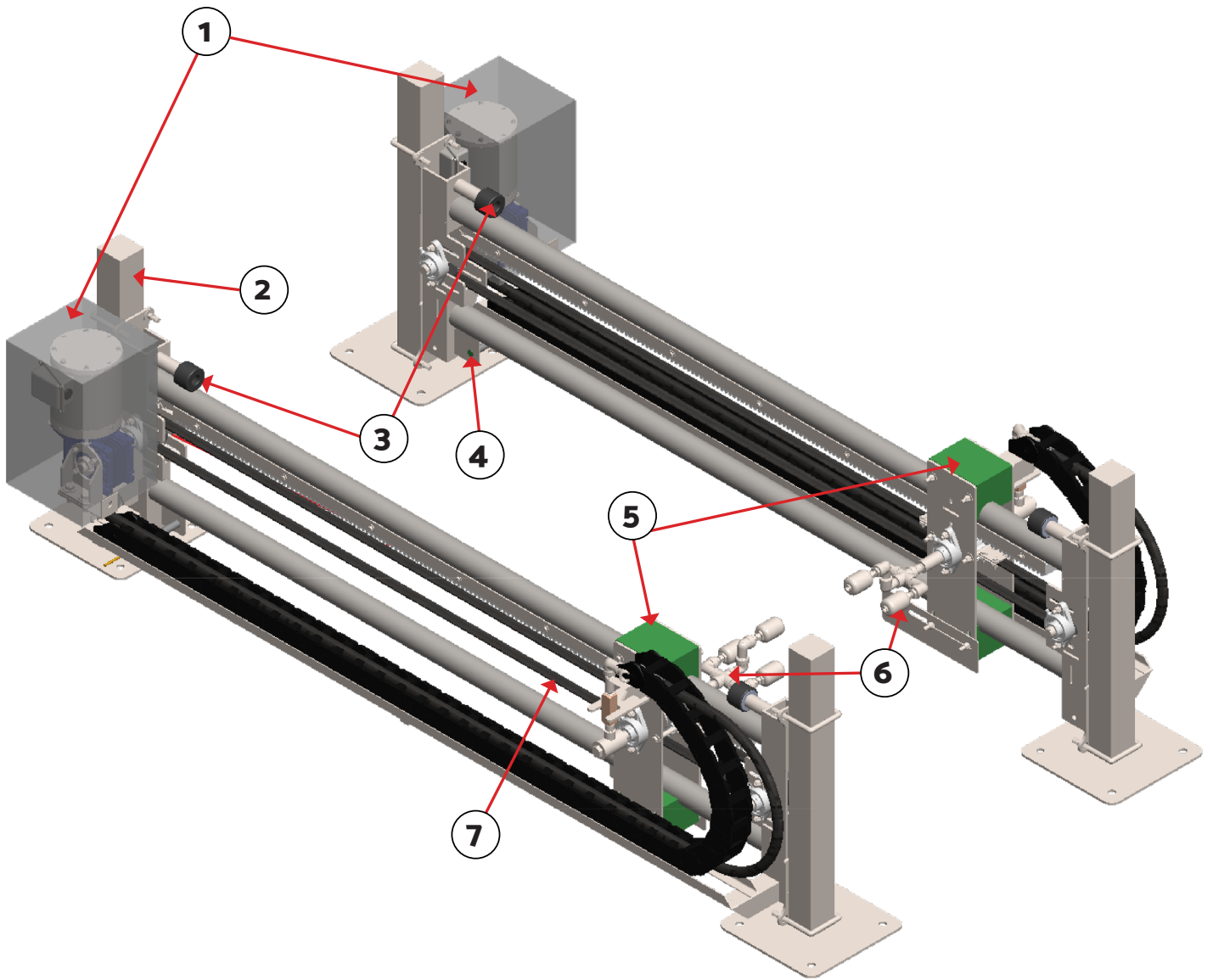

Fig. 2.1 - 1 - wheelblastIT identification

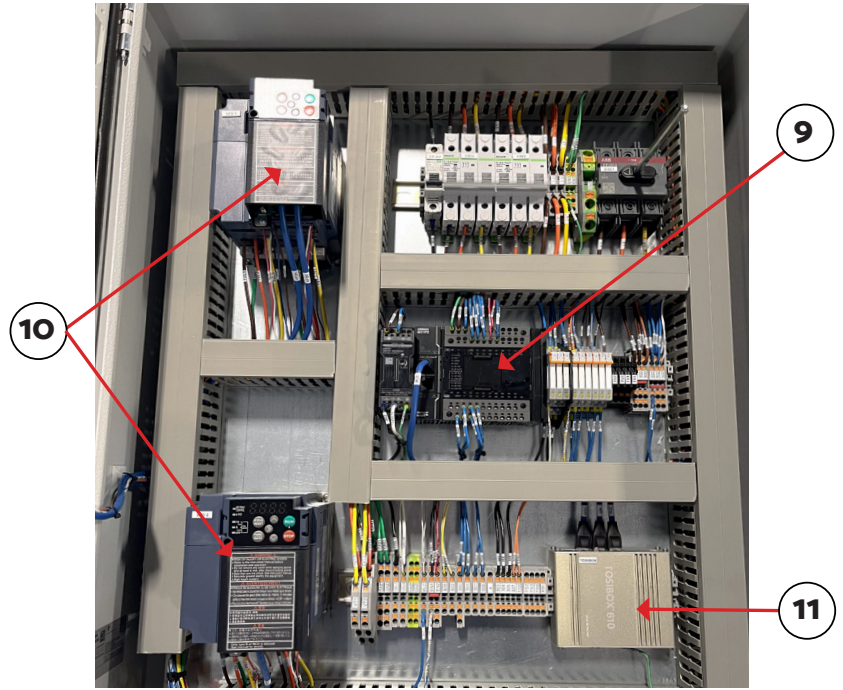

Fig. 2.1 - 2 - wheelblastIT electrical enclosure identification

Table 2.1 - 1 - wheelblastIT component features and functions

#	Component	Features/Functions
1	Motor Housing	- Protects motors and associated components from environmental elements and debris
2	Stainless Steel Frame	- Stainless steel construction maximizes durability and equipment longevity
3	Bumpers	- Absorb and mitigate impact if the trolley reaches the end of its travel path, preventing damage
4	Proximity Sensor	- Ensures trolleys return to their home position before beginning movement for consistent operation
5	Slide Blocks	- Facilitates smooth and stable movement of the trolleys along the rails, reducing wear and tear on the system
6	Rotating Nozzles	- Rotating assembly with three nozzles per trolley that spray high-pressure water to effectively remove dirt, grime, and brake dust from wheels
7	Drive Belt	- Connection between the gear box and the trolley
8	HMI	- Provides feedback on system operation - Allows for rapid troubleshooting and fine-tuning of system performance
9	PLC	- Manages trolley movements, calculates travel distances, and integrates sensor inputs for system control

#	Component	Features/Functions
10	VFDs	- Control trolley speed by adjusting the frequency, ensuring precise and consistent movement
11	Tosibox	- Provides remote VPN access for reliable support and troubleshooting

2.2 System Specifications

Table 2.2 - 1 - wheelblastIT specifications

Maximum Output (Per Side)	4.5 GPM <i>Dependent on operating pressure</i>
Minimum Water Supply Pressure	600 psi
Maximum Water Supply Pressure	1000 psi
Water Connection (Per Side)	1/2" MNPT
Voltage	208 VAC/3PH 480 VAC/3PH
Max Current	7 A (208) 3 A (480)
Dimensions (Per Side)	99" w x 30.5" h x 27" d
Max Travel Distance	60"

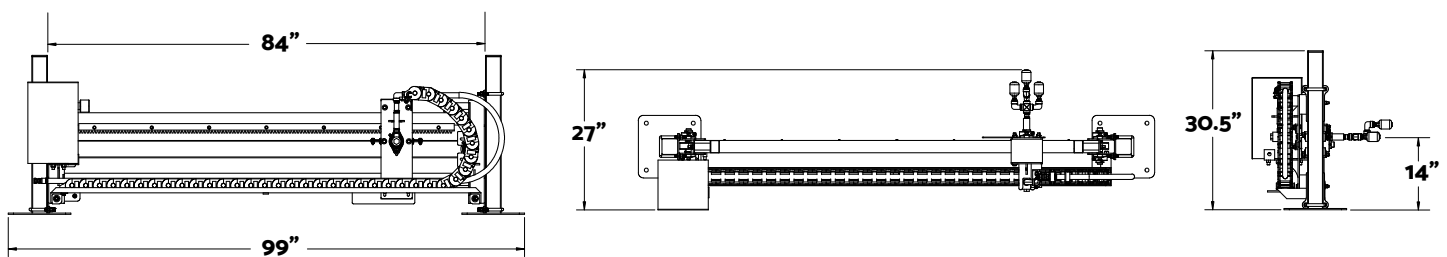

Fig. 2.1 - 3 - wheelblastIT dimensions

Installation

3. Installation

Installation of the wheelblastIT must conform to local plumbing, electrical, and sanitation codes. The customer is responsible for obtaining all permits and ensuring the following conform to all state and local codes before installing the wheelblastIT.

3.1 Installation Preparation

Locate where the equipment will be installed with your installer. The wheelblastIT should be installed in the tunnel where the vehicle's forward motion is stable and consistent.

3.2 Mechanical Installation

The goal is to position the main frame rail of the wheelblastIT assembly to be 24" from the outside wheel face. The distances listed below and shown in Fig. 3.1 - 1 and Fig. 3.1 - 2 reflect the recommended placement in typical installations.

- **Standard Conveyor**
 - **Driver Side**
 - 38" off the conveyor's inner rail
 - **Passenger Side**
 - 92" off the conveyor's inner rail
 - **Belt Conveyor**
 - **Driver Side/Passenger Side**
 - 24" from the outer edge of the belt
1. If using the wheelblastIT controller, determine where the electrical enclosure will be placed in your backroom. Take into consideration the following points:
 - Access to HMI screen
 - Location of 3ph electric supply for the system
 - Location of control wiring from tunnel controller for the system
 - Location of any equipment that may be spraying water
 2. Once the wheelblastIT is positioned in you tunnel, place a level on each vertical post to ensure the unit is level. Next, place a level across the top rail and ensure the unit is level.

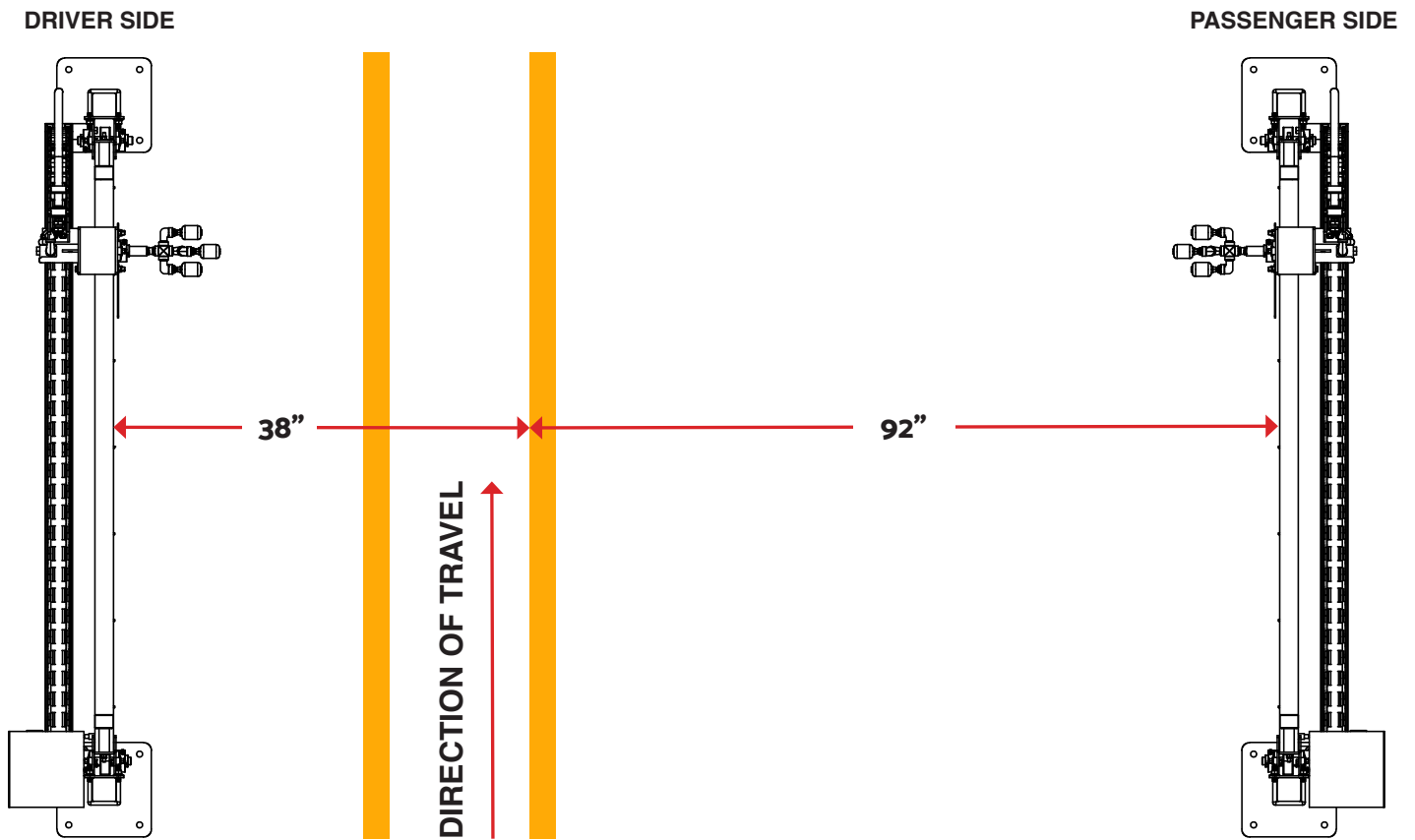

Fig. 3.1 - 1 - Standard chain conveyor placement of wheelblastIT assemblies

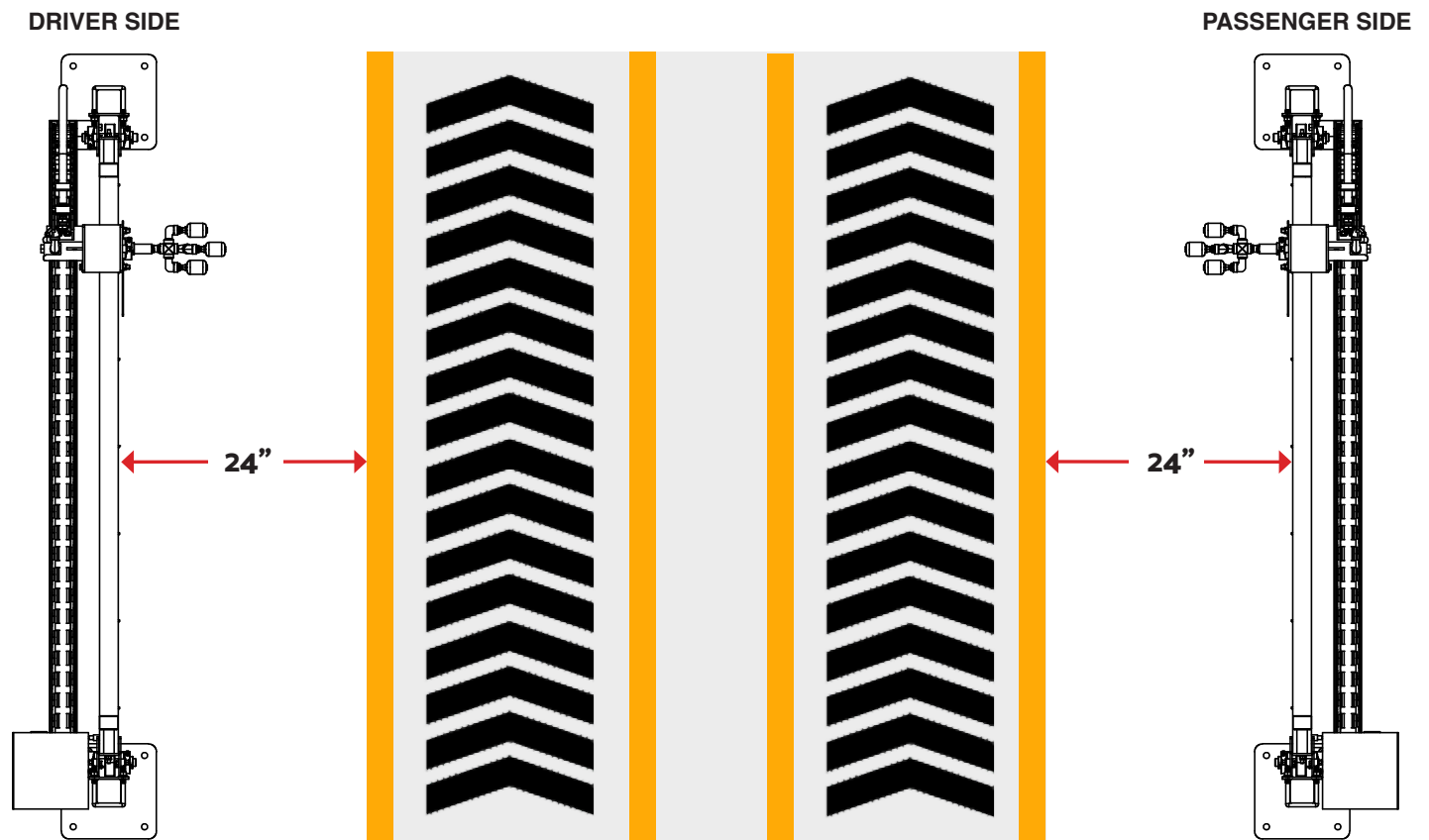

Fig. 3.1 - 2 - Belt conveyor placement of wheelblastIT assemblies

3.2.1 Installing Water Lines

1. Connect the HP water hose from the wheelblastIT energy chain to your high-pressure pumping station (pumping station not included).
 - Pumping station requires 10-12 gpm @ 800psi
 - Recommended: (1) ¾" stainless steel line from pumping station to the location of the wheelblastIT, then split to (2) ½" lines extending to each assembly

3.3 Electrical Installation

WARNING!

Electrical installation to be performed by a qualified electrician.
Follow all local codes.

NOTE

When installing cable connections, use dielectric grease of NLGI viscosity grade 2 to minimize the potential for water intrusion shorting the sensor signal or corroding the pins.
Reapply whenever cable is disconnected from sensor.

The electrical schematics and connection points in the controller are designated in **Appendix 2**.

1. Confirm system voltage prior to starting electrical installation.
2. Run provided sensor cables from innovateIT electrical enclosure to each wheelblastIT assembly. Do not run the sensor cable parallel to any high voltage lines.
3. Make electrical connections as listed in the tables below.

Table 3.3 - 1 - 208V/480V Voltage Connections

Enclosure Terminal	Connection
L1	Customer supplied 208V or 480V
L2	Customer supplied 208V or 480V
L3	Customer supplied 208V or 480V

Table 3.3 - 2 - 120V Connections

Enclosure Terminal	Connection
120L	Customer supplied 120V supply
120LN	Customer supplied neutral
GND	Customer supplied ground

Table 3.3 - 3 - Driver Side/Passenger Side Motor Connections

Enclosure Terminal	Connection
1VT1	Driver side 208V or 480V
1VT2	Driver side 208V or 480V
1VT3	Driver side 208V or 480V
1VT GND	Drive side ground
2VT1	Passenger side 208V or 480V
2VT2	Passenger side 208V or 480V
2VT3	Passenger side 208V or 480V
2VT GND	Passenger side ground

Table 3.3 - 4 - Tire Eye A (Optional)

Enclosure Terminal	Connection
FS2	Brown (24 VDC)
900	Black (Load - NPN)
502	Blue (0 VDC)

Table 3.3 - 5 - Tire Eye B (Optional)

Enclosure Terminal	Connection
FS3	Brown (24 VDC)
901	Black (Load - NPN)
502	Blue (0 VDC)

Table 3.3 - 6 - Driver Side Home Proximity Sensor

Enclosure Terminal	Connection
FS4	Brown (24 VDC)
907	Black (Load - NPN)
502	Blue (0 VDC)

Table 3.3 - 6 - Passenger Side Home Proximity Sensor

Enclosure Terminal	Connection
FS5	Brown (24 VDC)
908	Black (Load - NPN)
502	Blue (0 VDC)

Table 3.3 - 7 - Tunnel Controller inputs

Enclosure Terminal	Connection
303	CR1 - A1 (120 VAC or 24 VAC/DC - Tunnel Function/WB Start Command)
304	CR2 - A1 (120 VAC or 24 VAC/DC - Conveyor Running)
305	CR3 - A1 (120 VAC or 24 VAC/DC - Collision Monitoring)
600	CR4 - A1 (Pulse Switch)
602	CR4 - A2 (Pulse Switch)
307	CR5 - 11 (WB Water Solenoid Output - Dry Contact)
1700	CR5 - 14 (WB Water Solenoid Output - Dry Contact)

- Run customer supplied power (3PH) to DISC1 according to the system schematic (Fig. 3.3 - 1).



Fig. 3.3 - 1 - Customer 3PH connection

- Connect 120VAC to the 120L1, 120LN, and ground terminal located in wheelblastIT electrical enclosure. (Fig. 3.3 - 2).

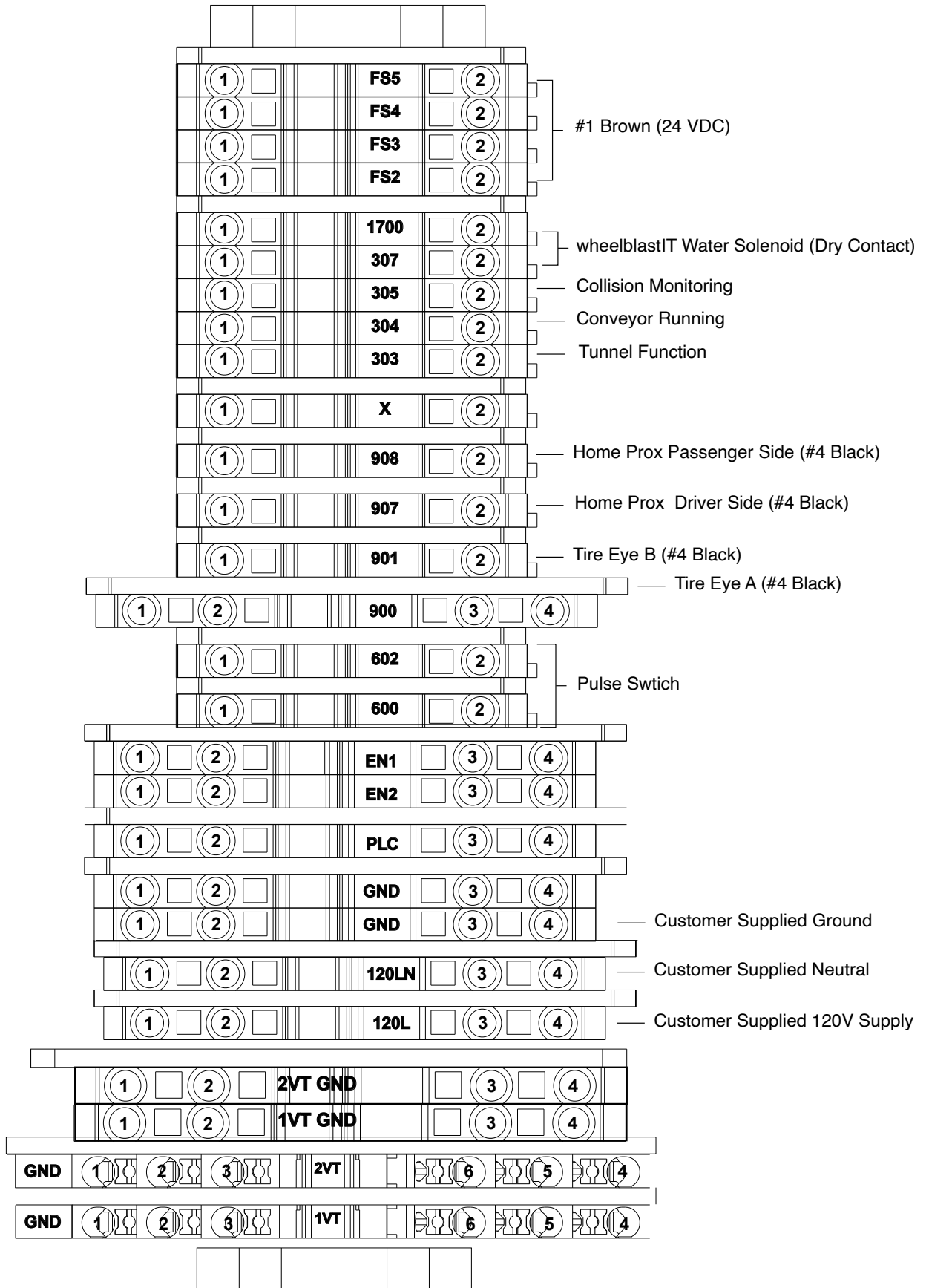

Fig. 3.3 - 2 - Electrical enclosure terminal strip connections

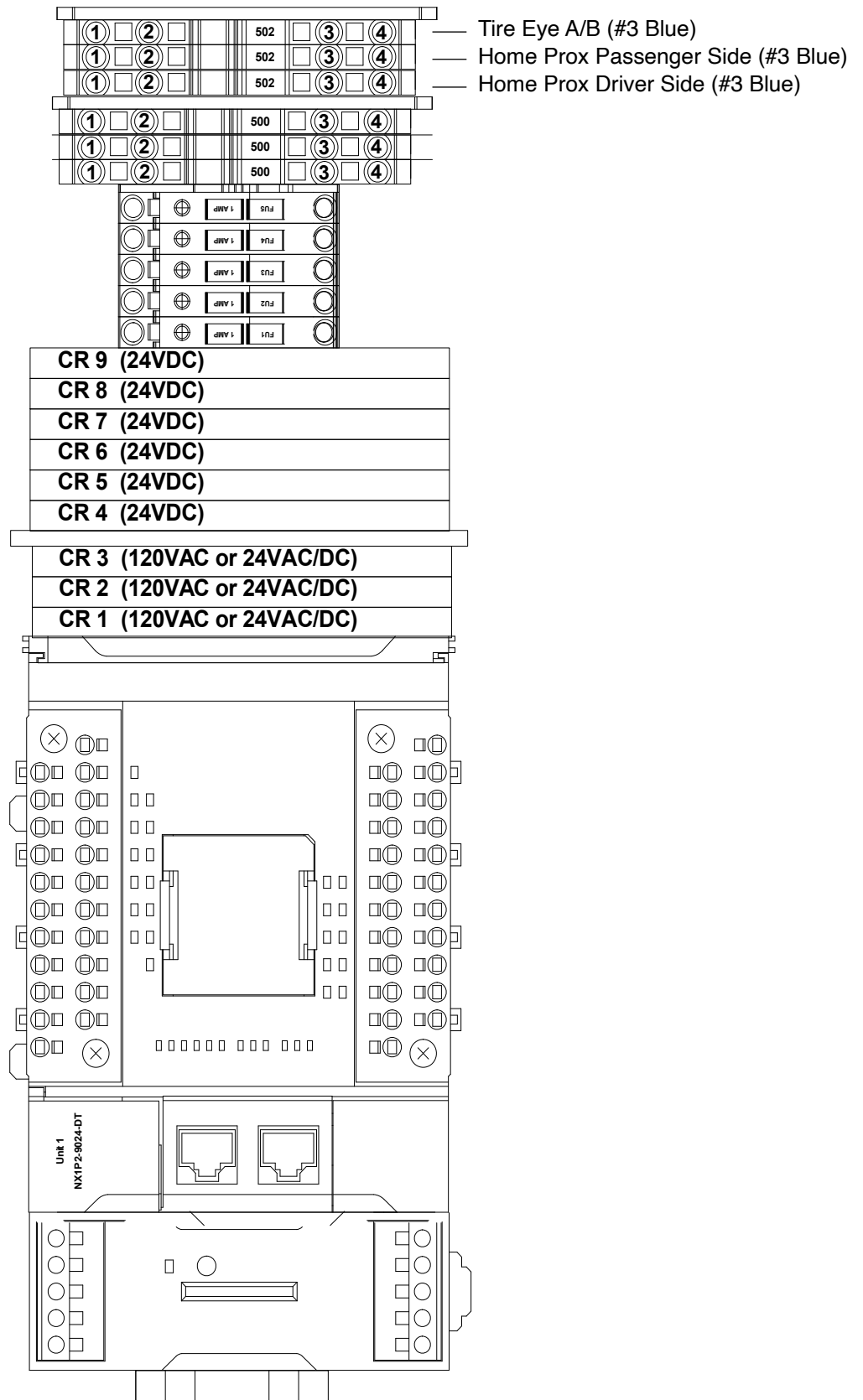

Fig. 3.3 - 3 - Electrical enclosure terminal strip connections

3.3.1 Water Solenoid Setup

Below are detailed instructions for the water solenoid setup within the wheelblastIT system. The configurations listed ensure that the wheelblastIT controller correctly manages water flow and pump operations in accordance with the trolley's position and forward travel. The setup variations are based on the specific type of pump and control method utilized.

1. Single Pump Controlled by a Motor Starter (No Solenoid Involved)

This configuration is applicable when a single pump, controlled by a motor starter, is dedicated exclusively to the wheelblastIT without involving a solenoid.

- **Power Supply Configuration:**
 - The tunnel controller supplies power to the motor starter based on the required voltage.
 - **For 120V** applications, constant power (hot) from the tunnel controller should be connected to terminal 307.
 - **For 24V** applications, constant power (hot) should be connected to terminal 107.
- **Control Signal Setup:**
 - Terminal 1700 serves as the “controlled hot” that connects to the motor starter’s A1 terminal.
 - A2 terminal of the motor starter should be connected to the neutral line that the tunnel controller uses for other motor starters.

2. Pump Controlled by a Variable Frequency Drive (VFD) Dedicated to wheelblastIT

In this configuration, a VFD is used to control the pump exclusively for the wheelblastIT operation.

- **Power Supply Configuration:**
 - **For 120V** applications, the common of the “VFD FWD” command should be connected to terminal 307.
 - **For 24V** applications, connect the common to terminal 107.
- **Control Signal Setup:**
 - The “VFD FWD” terminal of the VFD should be connected to terminal 1700.

3. Shared Pump Controlled by Tunnel Controller with a Separate Solenoid for wheelblastIT

This setup applies when a single pump is utilized for multiple high-pressure applications within the tunnel, but a separate solenoid is employed specifically for the wheel blaster.

- **Pump Operation:**
 - The tunnel controller is responsible for starting the pump.
 - Ensure that the tunnel controller is programmed to keep the pump running for the entire duration the car is at the wheel blaster.
- **Power Supply Configuration for the Solenoid:**
 - **For 120V** applications, constant power (hot) from the tunnel controller should be connected to terminal 307.
 - **For 24V** applications, connect the power to terminal 107.
- **Control Signal Setup for the Solenoid:**
 - Terminal 1700 serves as the “controlled hot” that connects to the solenoid’s A1 terminal.
 - The A2 terminal of the solenoid should be connected to the neutral line that the tunnel controller uses for other solenoids.

3.3.2 Remote Connection

The Tosibox in the electrical enclosure will provide the innovatIT technical support staff remote access to your wheelblastIT control system.

1. Connect ethernet cable from your router or network switch to the Tosibox WAN port (Fig. 3.3.1 - 1).

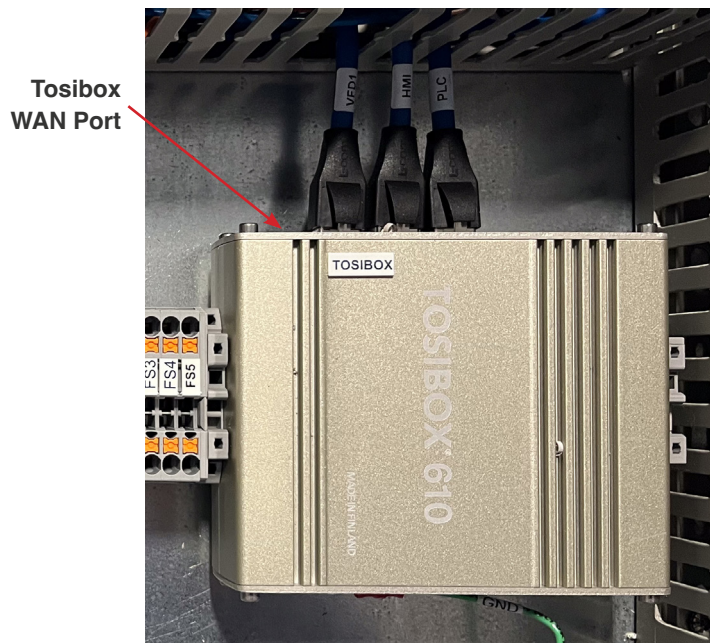

Fig. 3.3.2 - 1 - Tosibox WAN port connection for remote support

3.3.3 Setting wheelblastIT Tunnel Controller Function

1. Begin by assigning the wheelblastIT its own function in the tunnel controller (if needed, contact your tunnel controller provider for assistance).
2. Enter the distance from your tire switch to the wheel blaster spray nozzles.
3. Subtract 12" and set that value in the tunnel controller.
4. Enter the length for which the function will be on (approximately 12").
5. Assign output relay in tunnel controller that will be used (if needed, contact your tunnel controller provider for assistance).

Startup & Operation

4. Startup & Operation

⚠ WARNING!

Check and verify the tightness of all power distribution lines (screw terminals) before the startup process.

NOTE

Ensure all steps and precautions in Section 3 have been completed before starting up the wheelblastIT

4.1 Turning On Power Supply

1. Turn on 120VAC control circuit (CB 302) for the electrical enclosure (Fig. 3.3 - 1).
2. Turn on the 3PH power circuit (CB1V/CB2V) for the VFDs (Fig. 3.3 - 1).
3. Turn on wheelblastIT power via the rotary switch on the front of the electrical enclosure.

4.2 Conveyor Set Up

1. From the **Main** screen, press the **Settings** button (Fig. 4.2 - 1).

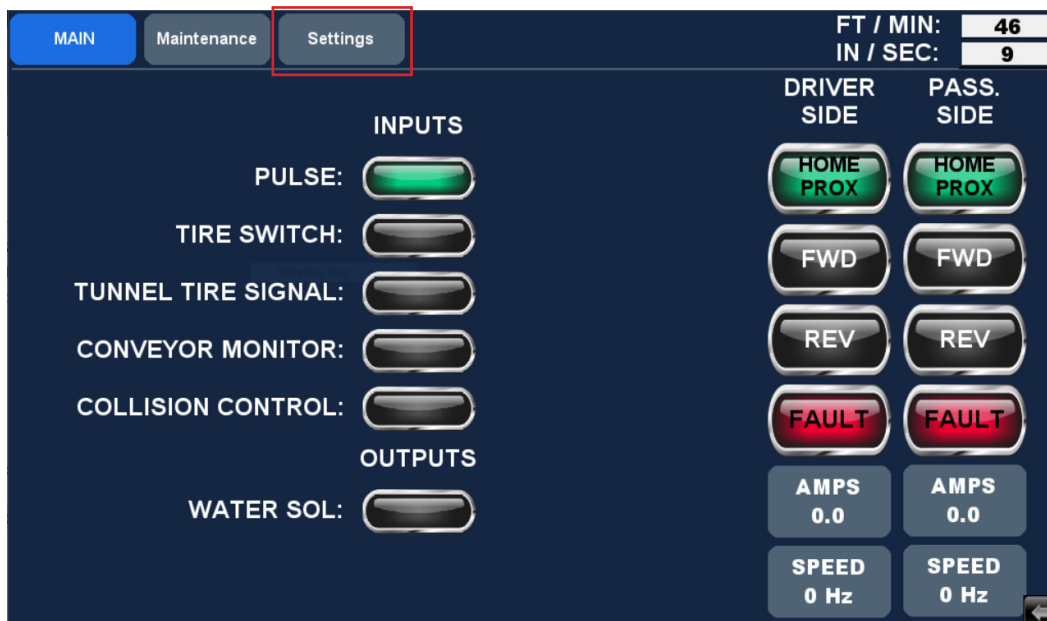

Fig. 4.2 - 1 - HMI Main screen

2. Enter the information for your specific conveyor set up.
 - This information should be obtained from your tunnel controller. This must be correct to ensure proper system performance. The definition of each setting is listed below:

- **Conveyor Inches Per Revolution:** How far the chain travels per revolution of the drive sprocket.
- **Pulses Per Revolution:** Number of pulses the system receives per revolution of the drive sprocket. It is recommended this setting remain at 1.
- **Slower Speed Modification:** Desired percentage to specify how much slower the trolley should run compared to the conveyor. This is most commonly used for belt conveyors where the vehicle's wheel is not rotating to ensure the spray pattern runs through the wheel.
- **WB Starting Position:** Set to 1 if using a tunnel tire signal. If using tire eyes, move the trolley to the entrance end of the trolley and measure the distance from the tire eyes to the center of the trident. Enter this value.
- **Travel Distance:** Total travel distance of the trolley.

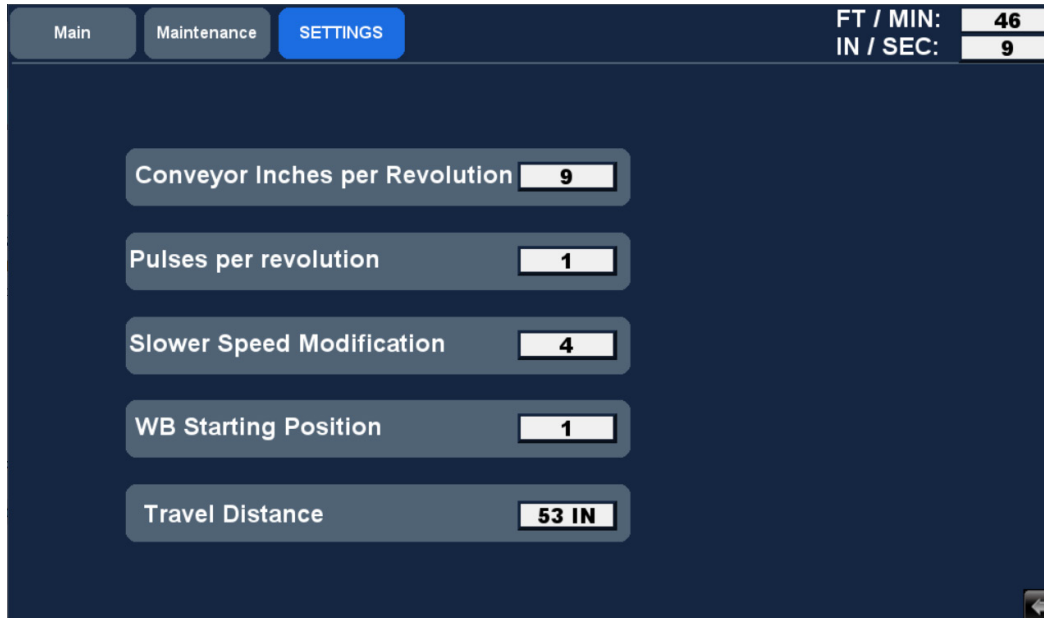

Fig. 4.2 - 2 - HMI Settings screen

4.3 Starting Trolley Movement

Once all of information is correct in your conveyor setup, you'll begin the process of ensuring the wheelblastIT trolleys movement is correct.

1. Using your hand, push both trolleys to the middle of their travel path.
2. With one person watching the main screen and one person at the wheelblastIT, place a metal object in front of the driver's side proximity switch.
3. Navigate to the **Main** screen and confirm the **DRIVER SIDE 'HOME PROX'** button is green. (Fig. 4.3 - 1).
4. Repeat for the passenger's side and confirm the **PASS. SIDE 'HOME PROX'** button is green (Fig. 4.3 - 1). **Do not proceed until this is correct.**

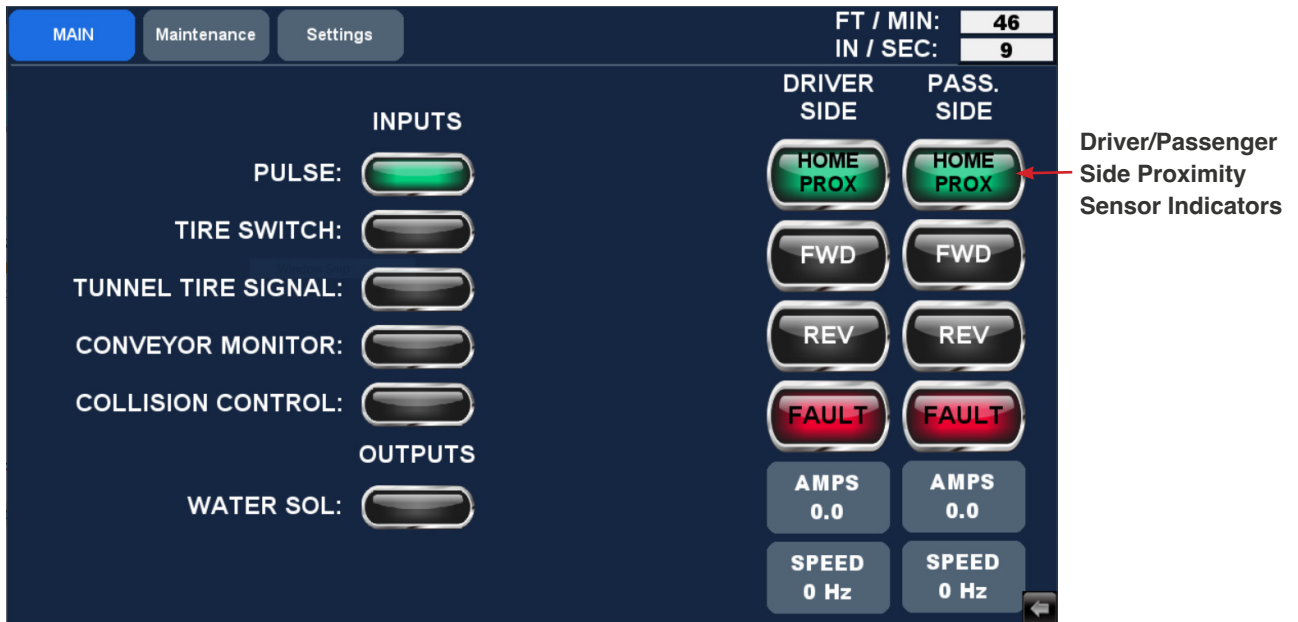

Fig. 4.3 - 1 - Main screen proximity sensor indicators

4.4 Verifying Motor Rotation

Next, verify the rotation of the motors to ensure they are wired correctly.

1. Using your hand, push both trolleys to the middle of their travel path.
2. Verify 3PH power is on.
3. Turn the **Main Disconnect** switch on the front of the electrical enclosure to the **ON** position if not already done.
4. Turn on disconnects inside the control panel for each motor.
5. Verify that the VFDs light up.
6. Ensure both trolleys are in the middle of their travel path.
7. Navigate to the **Maintenance** screen.
8. Press the '**FORCE TROLLEYS FORWARD**' button momentarily (Fig. 4.4 - 1).

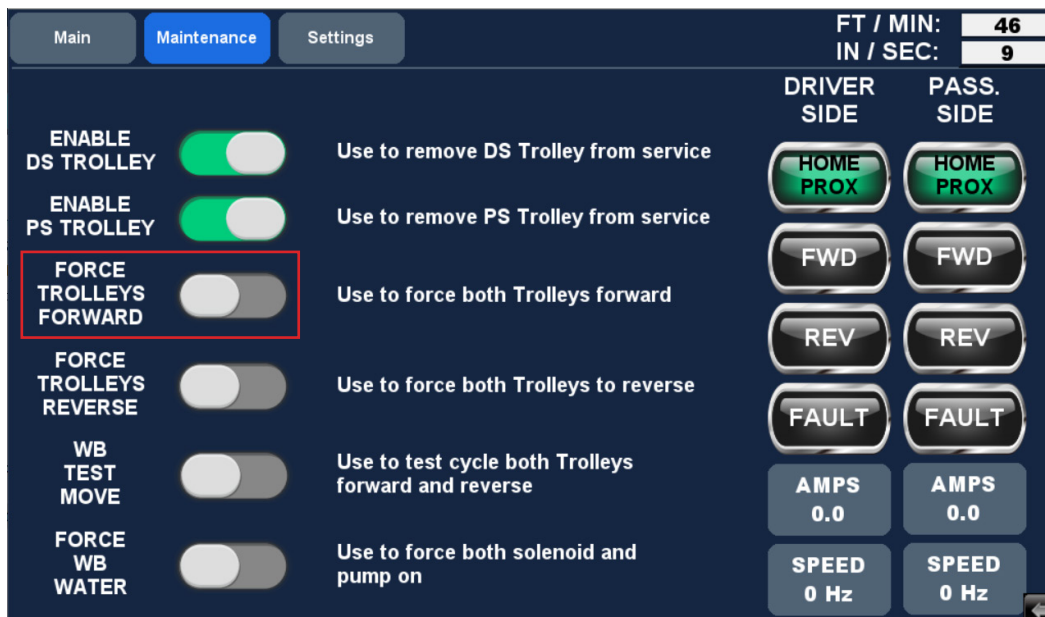

Fig. 4.4 - 1 - HMI Maintenance screen

- If incorrect, a qualified electrician should switch 2 of the wires going to the motor at the terminal strip to reverse rotation.
9. If rotation is incorrect, turn the **Main Disconnect** switch on the front of the electrical enclosure to the OFF position.
 10. Turn off 3PH power and wait until the VFD display turns off.
 11. Have a qualified electrician switch the wires as described in step 7.
 12. Re-test the system by following steps 1-7.

4.5 Testing the System

1. Navigate to the **Main** screen. Below is what is displayed by each input/output indicator (Fig. 4.5 - 1).
 - **Pulse:** Pulse was received on the PLC.
 - **Tire Switch:** Signal was received from tire eye or tire pad.
 - **Tunnel Tire Signal:** Tunnel controller tire signal was received.
 - **Conveyor Monitoring:** Conveyor is on.
 - **Collision Control (optional):** Pauses wheelblastIT in its current position.
 - **Water Solenoid (optional):** Water output solenoid that will turn on when the wheelblastIT begins its movement and turn off when it returns to the home position.

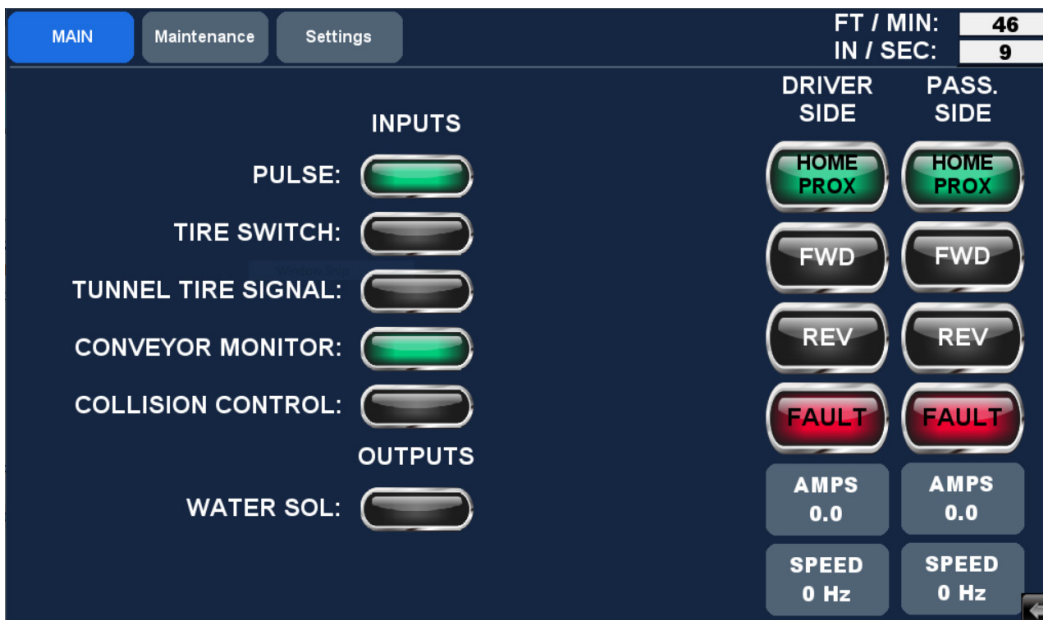

Fig. 4.5 - 1 - HMI Main screen indicators

2. Verify that you are getting a tire signal input indicator is green.
 - If using tire eyes, place a hand in front of the eyes and verify that the **'TIRE SWITCH'** indicator is green
 - If using a tire function, override the function in your tunnel controller and verify that the **'TUNNEL TIRE SIGNAL'** indicator is green.
3. With the conveyor running, verify that the **'CONVEYOR MONITOR'** indicator is green.
4. With the conveyor running, verify that the **'PULSE'** indicator is blinking green every time you get a pulse.
5. If the rotation is correct, the home sensors are functioning, the pulse signal is correct, and conveyor bit lamp is lit, proceed to the next step. **If any of the above conditions are not met do not proceed.** Return to previous steps to determine the issue.
6. Navigate to the **Maintenance** screen.
7. With conveyor running press the **'WB TEST MOVE'** button.

- The trolleys should move to the end of their travel path, stopping roughly $\frac{3}{4}$ ” from the rubber bumper, then return to the “Home” position.
 - If the trolleys hit the end bumper, navigate to the **Settings** screen and reduce the travel distance.
 - If the trolleys stop farther than $\frac{3}{4}$ ” from the end bumper, navigate to the **Settings** screen and increase the travel distance.

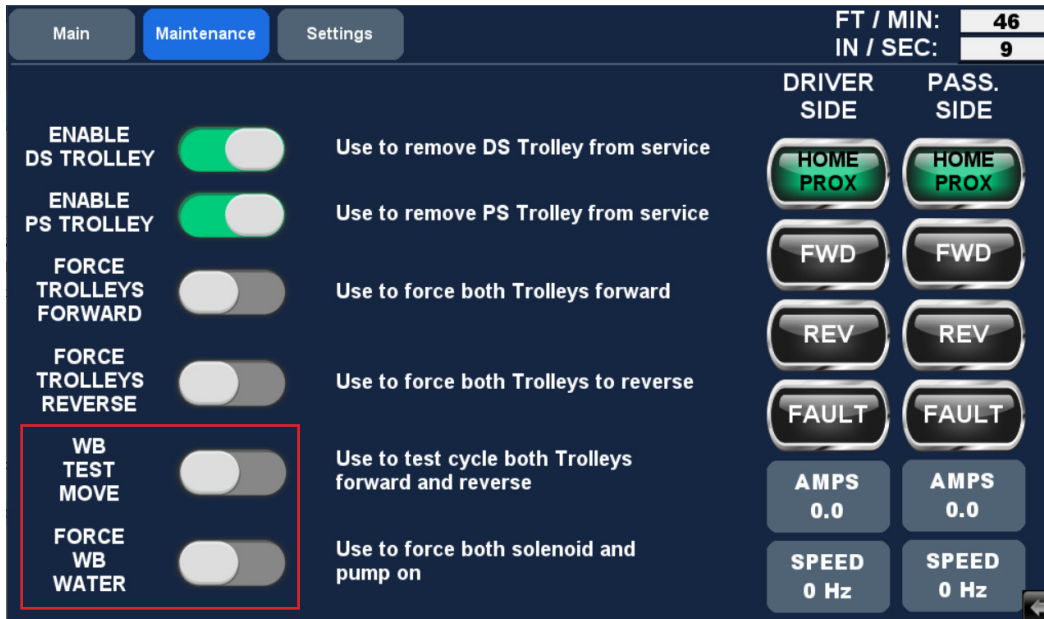

Fig. 4.5 - 2 - HMI Maintenance screen and WB TEST MOVE button

8. Once you’re satisfied with the motion, press the ‘**WB TEST MOVE**’ button once more to terminate the test procedure.
9. Press the ‘**FORCE TROLLEYS REVERSE**’ button to return the trolleys to the “Home” position.
10. Program and send a car through the wash. Verify that the wheelblastIT starts moving with the wheel. With the ideal start position, the spray pattern should focus on the leading edge of the tire where it meets the rim. At the end position, the spray pattern should be centered on the trailing edge of the tire where it meets the rim.
 - If the motion starts late, navigate to the **Settings** screen and reduce the ‘**WB Starting Position**’ number.
 - If the motion starts early, increase the ‘**WB Starting Position**’ number.

Service & Maintenance

5. Service & Maintenance

The best method to maintain the wheelblastIT is to take a few minutes daily to examine the unit for leaks or any indication of a mechanical or electrical fault.

If a change in performance or operation is observed, it is essential to take corrective action quickly to minimize the potential damage to the system.

There are elements of the system that will require normal maintenance actions. These items are listed in the following section.

5.1 Service Schedule

Table 5.1 - 1 - Service schedule

Check	Frequency	Process
Visual Inspection	Daily	<ul style="list-style-type: none">Wipe down the top guide rail.Inspect trolleys and slide blocks, and check for smooth movement. Ensure there are no obstructions on rails.
Grease Bearings	Weekly	<ul style="list-style-type: none">Grease all bearings on the water shaft, idler shaft, and drive sprocket (6 total).
Drive Belt Inspection	Quarterly	<ul style="list-style-type: none">Verify belt tension is correct. A belt deflection of 1.25" is recommended.To measure and/or adjust belt deflection, refer to Appendix 3.
Slide Block Inspection	Quarterly	<ul style="list-style-type: none">Inspect the slide blocks to ensure there is no excessive wear.Verify the gap between the bottom block and the bottom rail. A 3/32" gap is recommended. To adjust the bottom block gap, refer to Appendix 3.
Spur Gear Inspection	Quarterly	<ul style="list-style-type: none">Verify the gap between the spur gear and toothed rail. A 3/32" gap is recommended. To adjust the spur gear gap, refer to Appendix 3.
Home Proximity Sensor Inspection	Quarterly	<ul style="list-style-type: none">Verify the gap between the Home Proximity Sensor and the flag.A gap of 1/8" is recommended. To measure the gap and/or reposition the sensor, refer to Appendix 3.

Troubleshooting

6. Troubleshooting

For product support, contact support@innovateITcarwash.com, or call (518) 741-4200 (option 2).

Symptom	Potential Causes	Solution
Trolley Continuously Moving Forward	<ul style="list-style-type: none"> wheelblastIT PLC Heartbeat pulse is missing 	<ul style="list-style-type: none"> The wheelblastIT PLC must be power-cycled to return to normal operation. To power-cycle the PLC, toggle off, then on, circuit breaker "300" in the WB controls enclosure. Once the PLC has completed rebooting, the trolleys must returned to the Home position via the "Force Reverse" command on the HMI.
No Trolley Movement	<ul style="list-style-type: none"> Sensor cable connection 	<ul style="list-style-type: none"> Navigate to the Home screen on the HMI. Verify that the 'DS Home' and 'PS Home' buttons are green when the trolleys are in the Home position. If they do not turn green, verify the sensor cable connection and inspect for any damage. Replace the sensor cable.
	<ul style="list-style-type: none"> VFD fault 	<ul style="list-style-type: none"> Open the electrical enclosure and ensure both VFDs have power. If the lights on the VFD are blinking, it's not receiving a Run command. If there is a solid number displayed on the VFD, the Run command is present.
	<ul style="list-style-type: none"> Excessive belt tension 	<ul style="list-style-type: none"> Verify belt deflection and adjust as needed per the instructions in Appendix 3.
	<ul style="list-style-type: none"> Incorrect gap between spur gear and rack gear 	<ul style="list-style-type: none"> Verify gap between the spur gear and rack gear, and adjust as needed per the instructions in Appendix 3.
Both Trolleys Moving Slowly	<ul style="list-style-type: none"> Incorrect Conveyor Inches per Revolution setting 	<ul style="list-style-type: none"> Navigate to the Conveyor screen on the HMI and verify the Conveyor Inches per Revolution value. Adjust this value to match the conveyor settings.

Symptom	Potential Causes	Solution
One Trolley Moving Slowly	<ul style="list-style-type: none"> Incorrect slide block vertical adjustment 	<ul style="list-style-type: none"> Verify the gap between the bottom slide block and the bottom rail, and adjust as needed per the instructions in Appendix 3.
	<ul style="list-style-type: none"> Excessive belt tension 	<ul style="list-style-type: none"> Verify belt deflection and adjust as needed per the instructions in Appendix 3.
	<ul style="list-style-type: none"> Incorrect gap between spur gear and rack gear 	<ul style="list-style-type: none"> Verify gap between the spur gear and rack gear, and adjust as needed per the instructions in Appendix 3.
Faults During Trolley Movement	<ul style="list-style-type: none"> VFD has experienced a fault 	<ul style="list-style-type: none"> Examine the VFDs for the potential faults below: <ul style="list-style-type: none"> Motor amperage exceeding a programmed limit (typically 4.0 amps). Excess voltage during/shortly after transition from 'Reverse Fast Speed' to 'Reverse Slow Speed'.
Trolley Intermittently Failing To Return To 'Home' Position	<ul style="list-style-type: none"> Excess amperage fault 	<ul style="list-style-type: none"> Examine the trolley assembly and inspect the wheelblastIT's moving components for the potential issues below: <ul style="list-style-type: none"> Motors/pulleys seizing Material binding between gears Failed spur gear
Excess Voltage Fault - Error Codes 'OU2' or 'OU3' displayed on VFDs	<ul style="list-style-type: none"> "OU2" indicates excess voltage during deceleration "OU3" indicates excess voltage when running at constant speed 	<ul style="list-style-type: none"> Reduce 'Rev Fast Speed' or increase 'Rev Slow Speed'
Uneven wear on the sides of the belt	<ul style="list-style-type: none"> Idler and drive pulley shafts are not aligned at right angles (perpendicular) to the rails, causing the belt to rub against the pulley sidewalls 	<ul style="list-style-type: none"> Adjust shaft alignment using the steps below: <ol style="list-style-type: none"> Slightly loosening the plastic flanged shaft bearing assemblies with two 9/16" wrenches. GENTLY tap the shaft ends with a hammer. Tighten the bearing bolts before putting the trolley into test mode "Continuous Move". Put the trolley into 'Continuous Move' mode Observe belt position and ensure there is always at least a small gap between the belt and pulley sidewalls.

Symptom	Potential Causes	Solution
Water Shaft Spinning Inconsistently	<ul style="list-style-type: none"> Misalignment of spur gear and rack gear 	<ul style="list-style-type: none"> Water shafts assembled with spur gears cannot be switched between driver and passenger sides. When installing a new one-way bearing, ensure the bearing faces the correct direction for its use on the driver or passenger side. A fully assembled spur gear and water shaft assembly has the spur gear key slot facing the vehicle. The key slot side of the spur gear should be 4-3/8" from the 3-nozzle end of the water shaft. The driver side one-way gear should spin freely counterclockwise when viewed from the wall end of the water shaft. The passenger side spur gear should spin freely clockwise when viewed from the wall end of the water shaft.

Spare Parts

7.1 Recommended Spare Parts

Below is a list of recommended spare parts that may require replacement during the course of system operation. For parts ordering, please contact partsales@innovateITcarwash.com

innovateIT Product Number	Description
WB-BLT	Belt
9805293	1" x 7" Keyed Shaft
9806413	1" x 12" Keyed Shaft
1703375	Spur Gear Driver Side Assembly
1703376	Spur Gear Passenger Side Assembly
BRNG-1.0-2B	Bearings
ELE-SEN-18-IP-PNP	18mm Home Proximity Inductive Sensor (PNP)
ELE-SEN-18-IP-NPN	18mm Home Proximity Inductive Sensor (NPN)
6605696	18mm Home Proximity Inductive Sensor (NPN/PNP)
ELE-SEN-18R-IR	18mm Photoelectric Sensor, Receiver
ELE-SEN-18E-IR	18mm Photoelectric Sensor, Emittter
ELE-SEN-C-M12-25	25M M12 Cable
GRBX-5:1	Blue Aluminum Gear Box (Requires 4-hole pattern mount)
GRBX-SS-7:1	Stainless Steel Gear Box (Requires 12-hole pattern mount)
MTR-ELE-3/4	Motor
WB-NZZL-RO#4	Nozzle
WB-SLD-NYL	Slide Block
WB-SPROCKET-SS	Drive Sprocket
WB-TPRLCK-SS	Taperlock

7.2 Spare Part Replacement

7.2.1 Replacing Belt

The following tools are needed to complete this task:

- (2) 9/16" Wrench
- (2) 7/16" Wrench
- Ruler/Tape Measurer
- Rubber Mallet

1. Turn **Main Disconnect** switch on the front of the electrical enclosure to the **OFF** position and ensure that all outputs from the tunnel controller to the control solenoids for the wheelblastIT are turned OFF.
 - If wheelblastIT controls are integrated into sites tunnel controller, ensure all power (motor and control) to the wheelblastIT unit is turned OFF and all outputs to the control solenoids are turned OFF.

2. At the idler pulley, loosen the four nuts on the two plastic flanged shaft bearing assemblies (Fig. 7.2.1 - 1).

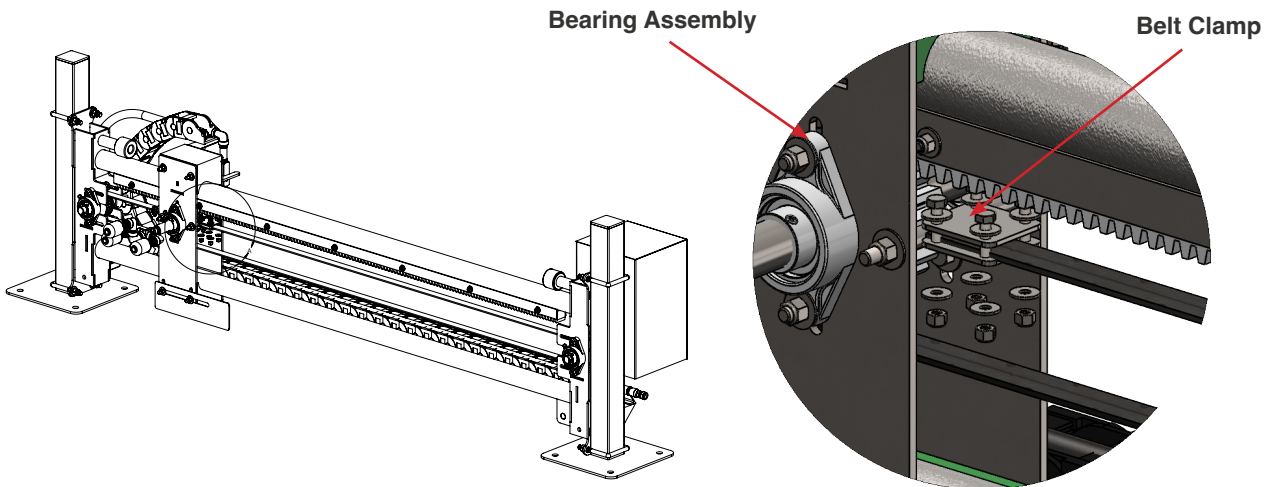

Fig. 7.2.1 - 1 - Belt removal

3. Gently tap the bearing assemblies with a rubber mallet to reduce tension on the belt.
4. Loosen the bolts on the belt clamps to release the belt.
5. Slide the belt off the drive and idler pulleys and carefully remove the belt.
6. Fully remove the belt clamps from the trolley (do not discard).
7. Position the new belt over the drive and idler pulleys. Ensure the belt is properly seated on both pulleys.
8. Place the ends of the belt into the belt clamps and tighten the bolts to secure the belt.
 - Ensure the grooves of the belt are aligned with the slots in the lower plate of the belt clamp.
9. Reinstall the belt clamps to the trolley.
10. At the idler pulley, gently tap the bearing assemblies with a hammer to adjust their position. Make sure the pulley shaft remains at a right angle (perpendicular) to the rails.
11. Use a ruler or tape measure to check the belt deflection and follow the instructions in Appendix 3 - Parts & Service Notes to set the proper belt deflection (1.25”).
12. Once the belt deflection is correct, tighten all four nuts on the bearing assemblies. Be sure not to overtighten bolts and bend trolley side plates in towards each other.
13. Turn the Main Disconnect switch on the front of the electrical enclosure to the ON position (re-establish power to the wheelblastIT).

7.2.2 Replacing Spur Gear & Water Shaft Assembly

The following tools are needed to complete this task:

- (2) 9/16” Wrench
 - (2) 7/16” Wrench
 - Pipe Wrench
1. Turn **Main Disconnect** switch on the front of the electrical enclosure to the **OFF** position.
 - If wheelblastIT controls are integrated into sites tunnel controller, ensure all power (motor and control) to the wheelblastIT unit is turned OFF and all outputs to the control solenoids are turned OFF.
 2. Loosen the bolts holding bearings at the end of the belt (Fig. 7.2.2 - 1). This will be the end opposite the motor (traditionally exit end of wash).

3. Slide the bearings forward to relieve tension.
4. Remove the bolts holding the belt clamps onto the trolley carriage (Fig. 7.2.2 - 1).

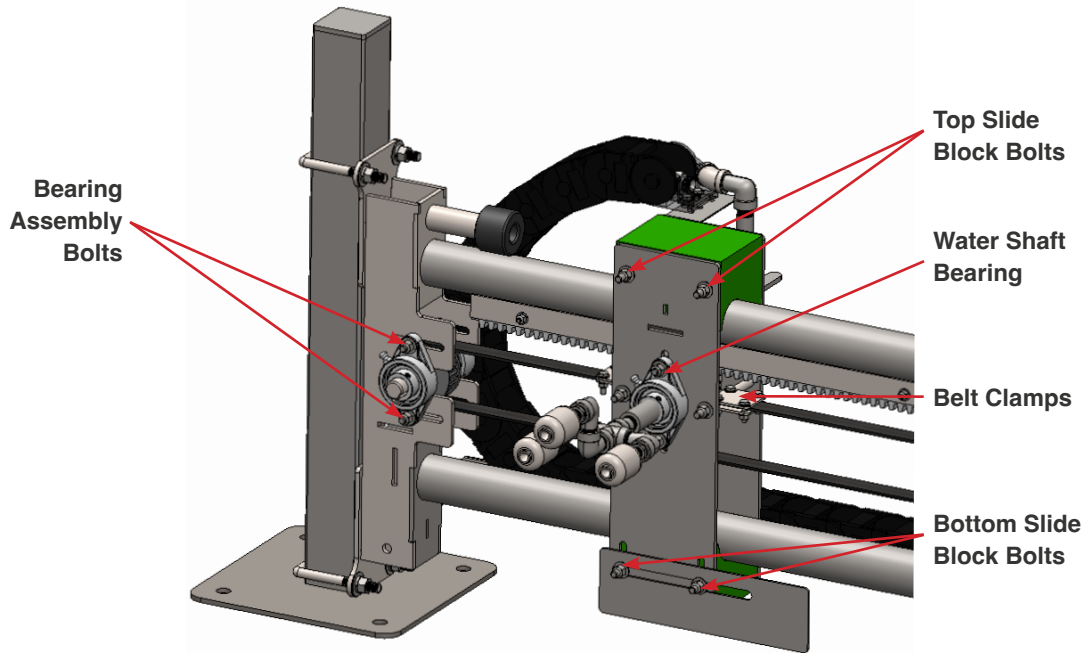

Fig. 7.2.2 - 1 - Bearings, slider block, and belt clamp bolt locations

5. Remove the bolts holding the bottom slide block and trolley flag (Fig. 7.2.2 - 1).
 - This will most likely cause the carriage to swing slightly. Blocking can be used under the carriage for support.
6. Loosen the set screws on both the front (trident or car side) and rear (wall side) bearing holding the water shaft/trident (Fig. 7.2.2 - 2).

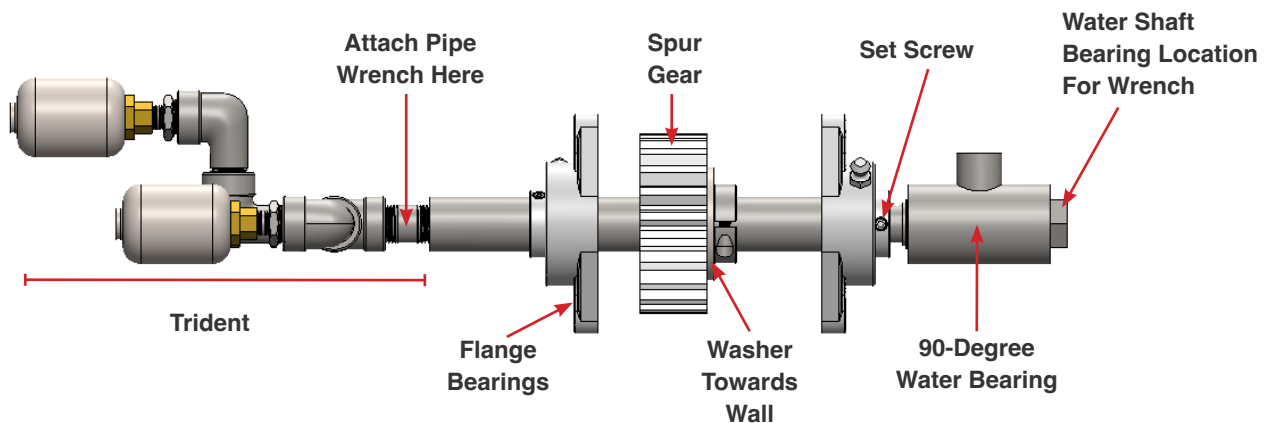

Fig. 7.2.2 - 2 - Water shaft assembly

7. Loosen, but do not remove, the top slide block bolts (Fig., 7.2.2 - 1).
8. Hold the trident end of the water shaft (ideally pipe wrench on the pipe nipple) and unthread the water shaft from the 90-degree water bearing on the wall side of the unit (Fig. 7.2.2 - 2).
 - Do not hold onto water shaft directly as it still needs to pass through the bearing to be removed.
9. Unthread the trident from the water shaft carefully to ensure the surface of the water shaft is not damaged.
10. Remove the bearing on the front of the unit holding the water shaft (Fig. 7.2.2 - 1).

11. Pull the water shaft out of the rear bearing and remove the assembly from trolley carriage.
12. Insert the new assembly into the rear bearing in the same orientation as before.
 - If installing a one-way bearing assembly, the washer on the spur gear should be towards wall.
 - If installing a bearing-free assembly, the shaft collar should be towards wall.
13. Reinstall the front bearing onto the water shaft and trolley carriage plate but keep the bolts loose on the plate.
14. Thread the trident onto the new water shaft assembly.
15. Thread the 90-degree water bearing onto water shaft assembly (Fig. 7.2.2. - 2).
 - Do not hold onto the water shaft directly as it still needs to pass through the bearing to be removed.
16. Adjust the spur gear to mesh with the gear rack and tighten flange bearings in place. Follow the instructions in Appendix 3 - Parts & Service Notes to properly mesh the spur gear and rack gear.
17. Reinstall the bottom slider block and trolley flag
18. Push up on the slider block to ensure proper fitting the of trolley carriage to the frame.
19. Reinstall the belt clamps onto the trolley carriage.
20. Tighten the upper slider block bolts.
21. Tighten the set screws on the bearings holding the water shaft/spur gear assembly.
22. Slide the bearings on and tighten the bolts holding the bearings.
23. Use a ruler or tape measure to check the belt deflection and follow the instructions in Appendix 3 - Parts & Service Notes to set the proper belt deflection (1.25").
24. Follow the instructions in Appendix 3 - Parts & Service Notes to ensure the trolley flag is in proper position.
25. Turn the Main Disconnect switch on the front of the electrical enclosure to the ON position (re-establish power to the wheelblastIT).

7.2.3 Replacing Home Proximity Sensor

The following tools are needed to complete this task:

- (2) 15/16" Wrench
- 1/8" Spacer

1. Turn the **Main Disconnect** switch on the front of the electrical enclosure to the **OFF** position and ensure that all outputs from the tunnel controller to the control solenoids for the wheelblastIT are turned OFF.
 - If wheelblastIT controls are integrated into sites tunnel controller, ensure all power (motor and control) to the wheelblastIT unit is turned OFF and all outputs to the control solenoids are turned OFF.
2. Move the trolley away from the Home position to create space for working.
3. Unscrew the sensor cable from the back of the home proximity sensor to minimize the chances of damaging the connection (Fig. 7.2.3 - 1, following page).

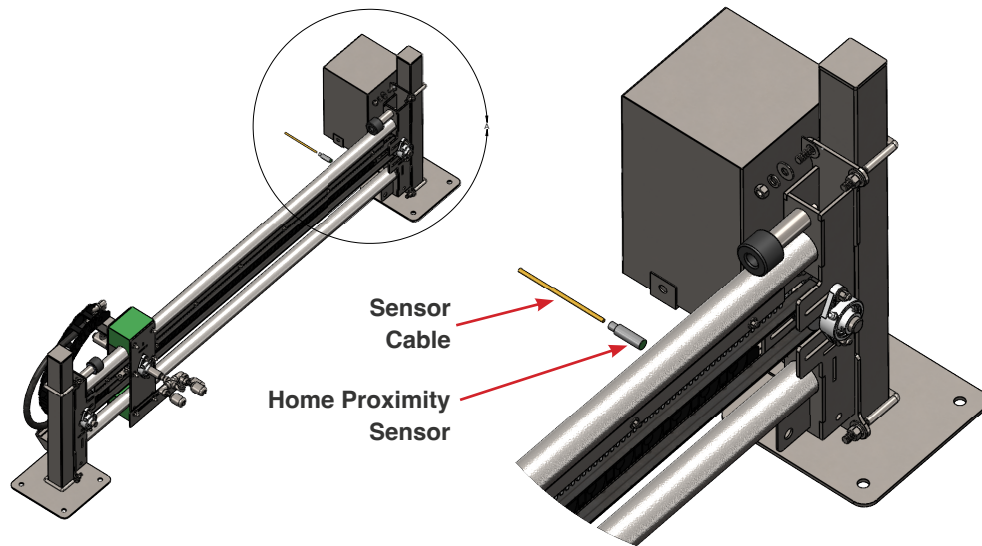

Fig. 7.2.3 - 1 - Home proximity sensor

4. Loosen the jam nuts and unscrew the sensor completely from its mounting.
5. Clean the sensor mounting area using a cleaning cloth.
6. Using a jam nut, position the new sensor until the face of the sensor is approximately 1.5" from the face of the sensors mounting plate.
7. Move the trolley until the flag covers the entire face of the sensor.
8. Insert the 1/8" spacer between the sensor and the flag to check the gap. The spacer should fit without extra space.
9. If the gap is not correct, adjust the position of the sensor by moving the jam nuts along the threaded barrel of the sensor until there is a gap of 1/8" between the sensor face and the flag.
10. Tighten the jam nuts and ensure the sensor is securely mounted and the gap remains correct.
11. Apply dielectric grease to the sensor connection.
12. Screw the sensor cable back onto the new home proximity sensor, ensuring a secure connection.
13. Turn the Main Disconnect switch on the front of the electrical enclosure to the ON position (re-establish power to the wheelblastIT).
14. Move the trolley back until the flag covers the face of the sensor and verify the proximity sensor is functioning properly (See Section 4.3).
15. Turn the Main Disconnect switch on the front of the electrical enclosure to the ON position (re-establish power to the wheelblastIT).

7.2.4 Replacing Slide Block

The following tools are needed to complete this task:

- (2) 9/16" Wrench
- (2) 7/16" Wrench

1. Turn the **Main Disconnect** switch on the front of the electrical enclosure to the **OFF** position and ensure that all outputs from the tunnel controller to the control solenoids for the wheelblastIT are turned OFF.
 - If wheelblastIT controls are integrated into sites tunnel controller, ensure all power (motor and control) to the wheelblastIT unit is turned OFF and all outputs to the control solenoids are turned OFF.

2. Position a block or support under the trolley so that it is fully supported.
3. Loosen and remove the top two bolts securing the top slide block to the trolley (Fig. 7.2.4 - 1).

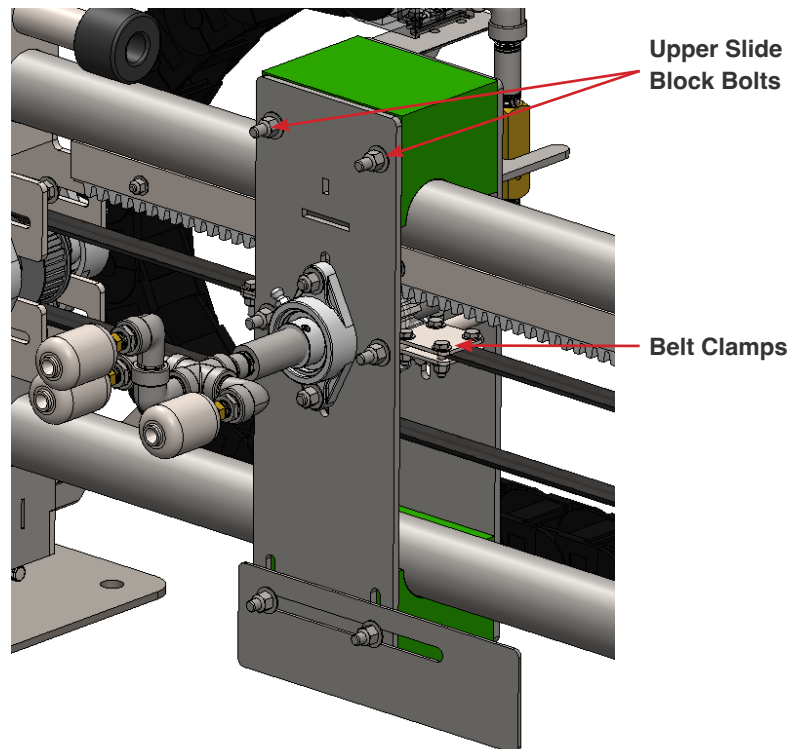

Fig. 7.2.4 - 1 - Replacing top slide block

4. Loosen the belt clamp bolts and set screws on the car side nozzle shaft clamp on the trolley so that the two trolley plates are loose and the top slide block can be easily removed.
5. Remove the top slide block.
6. Clean the rail and surrounding area using a cleaning cloth. Remove any debris, old lubricant, or corrosion to ensure a smooth installation of the new slide block.
7. Align the new slide block between the two trolley plates and with the rail and slide it into place. Ensure it is seated properly.
8. Reinsert and tighten the mounting bolts to secure the new slide block on the rail. Ensure the block is firmly in place and properly aligned.
9. Follow the instructions in Appendix 3 - Parts & Service Notes to reset the position of the bottom block to the bottom rail.
10. Move the trolley back and forth by hand along the length of the rail to ensure smooth and consistent travel.
11. Turn the Main Disconnect switch on the front of the electrical enclosure to the ON position (re-establish power to the wheelblastIT).

7.2.5 Replacing Belt Clamps

The following tools are needed to complete this task:

- (2) 9/16" Wrench
- (2) 7/16" Wrench

1. Turn **Main Disconnect** switch on the front of the electrical enclosure to the **OFF** position.
 - If wheelblastIT controls are integrated into sites tunnel controller, ensure all power (motor and control) to the wheelblastIT unit is turned OFF and all outputs to the control solenoids are turned OFF.

- Loosen the bolts holding bearings at the end of the belt (Fig., 7.2.5 - 1). This will be the end opposite the motor (traditionally exit end of wash).

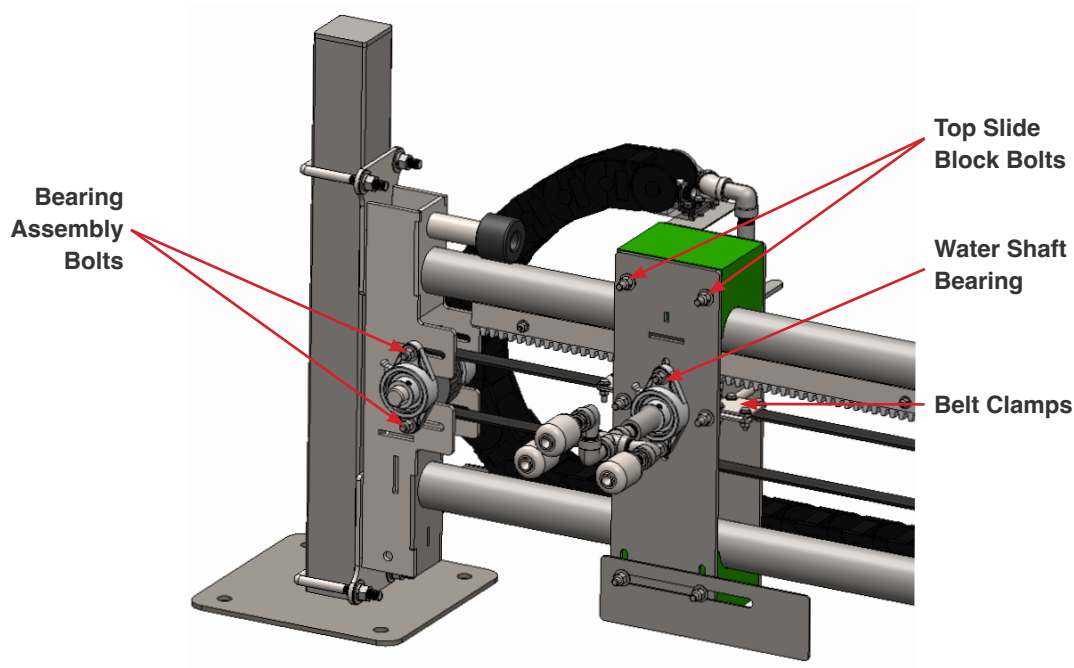

Fig. 7.2.5 - 1 - Replacing belt clamps

- Slide the bearings forward to relieve tension.
- Loosen the top slide block bolts.
- Remove the belt clamps from the carriage.
- Remove the 4 bolts holding the clamp together.
- Replace the belt clamp and reinstall onto belt
 - Be sure to fit the cogs in the belt into the grooves in clamp.
- Reinstall the clamp onto the carriage.
- Tighten the top slider block bolts.
- Slide the bearings on and tighten the bolts holding the bearings.
- Use a ruler or tape measure to check the belt deflection and follow the instructions in Appendix 3 - Parts & Service Notes to set the proper belt deflection (1.25").
- Follow the instructions in Appendix 3 - Parts & Service Notes to ensure the trolley flag is in proper position.
- Turn the Main Disconnect switch on the front of the electrical enclosure to the ON position (re-establish power to the wheelblastIT).

7.2.6 Replacing Drive Sprocket

The following tools are needed to complete this task:

- (2) 9/16" Wrench
- 3/16" Hex Driver

- Turn the **Main Disconnect** switch on the front of the electrical enclosure to the **OFF** position and ensure that all outputs from the tunnel controller to the control solenoids for the wheelblastIT are turned OFF.
 - If wheelblastIT controls are integrated into sites tunnel controller, ensure all power (motor and control) to the wheelblastIT unit is turned OFF and all outputs to the control solenoids are turned OFF.

2. Remove the motor cover.
3. Loosen the bolts holding bearings at the end of the belt (Fig. 7.2.6 - 1). This will be the end opposite the motor (traditionally exit end of wash).

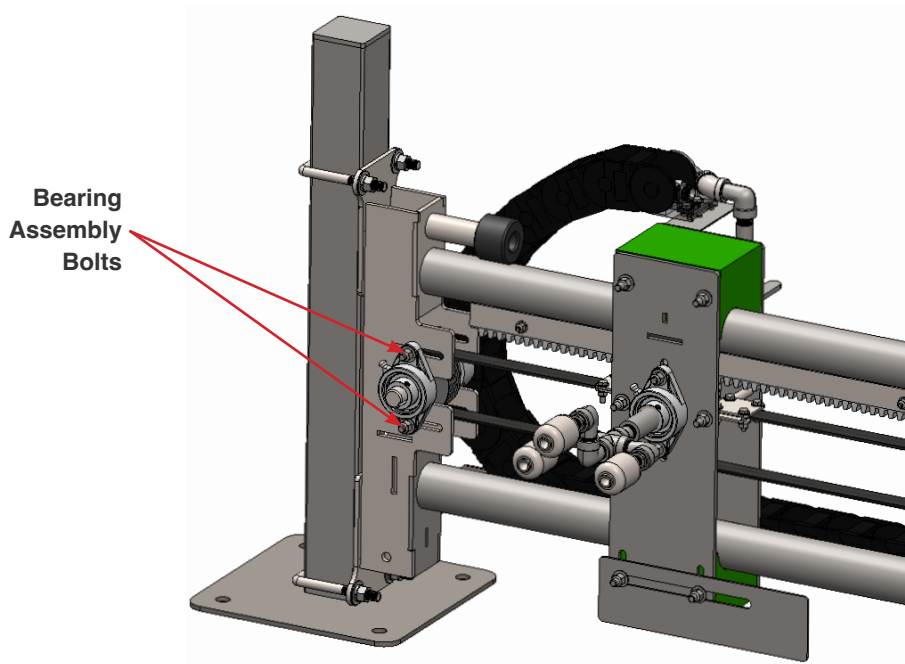

Fig. 7.2.6 - 1 - Belt bearing assembly bolt location

4. Locate the drive pulley and using a hex driver, loosen the shaft clamps on each side of the gear box and both bearing shaft collars holding the shaft (Fig. 7.2.5 - 2).

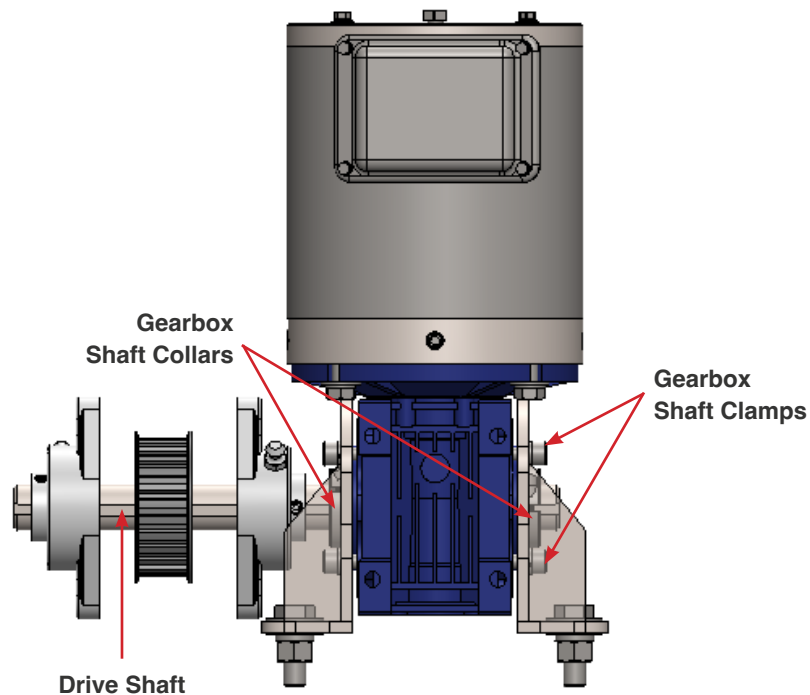

Fig. 7.2.6 - 2 - Gear box shaft clamps

5. Remove the car side bearing block.
6. Remove the set screws located in the sprocket hub to separate the keyed taper lock in the drive sprocket.
7. Slide the drive shaft out of the drive pulley towards the wall through the gearbox.

- Do not fully remove the drive shaft. Only push it back as far as the wall side bearing block so that the drive sprocket can be fully removed.
8. Clean the drive shaft and surrounding area using a cleaning cloth. Remove any debris, old lubricant, or corrosion to ensure a smooth installation of the new sprocket.
 9. Align the drive sprocket with the belt and slide the drive shaft through the new drive sprocket, ensuring it is properly seated and aligned.
 - Ensure that the keyed taper lock is installed in the central hub of the drive sprocket, but do not tighten the set screws.
 10. While maintaining the drive sprockets alignment with the belt, tighten the set screws for the taper lock on the new drive sprocket using an appropriate Allen wrench. Ensure the sprocket is firmly in place and properly aligned.
 11. Install the car side bearing block removed in Step 5.
 12. Tighten the bearing set screws and shaft collar bolts to secure the drive shaft.
 13. Turn the Main Disconnect switch on the front of the electrical enclosure to the ON position (re-establish power to the wheelblastIT).

7.2.7 Replacing Gearbox

1. Turn **Main Disconnect** switch on the front of the electrical enclosure to the **OFF** position.
 - If wheelblastIT controls are integrated into sites tunnel controller, ensure all power (motor and control) to the wheelblastIT unit is turned OFF and all outputs to the control solenoids are turned OFF.
2. Loosen the bolts holding bearings at the end of the belt (Fig. 7.2.7 - 1). This will be the end opposite the motor (traditionally exit end of wash).
3. Slide the bearings forward to relieve tension.

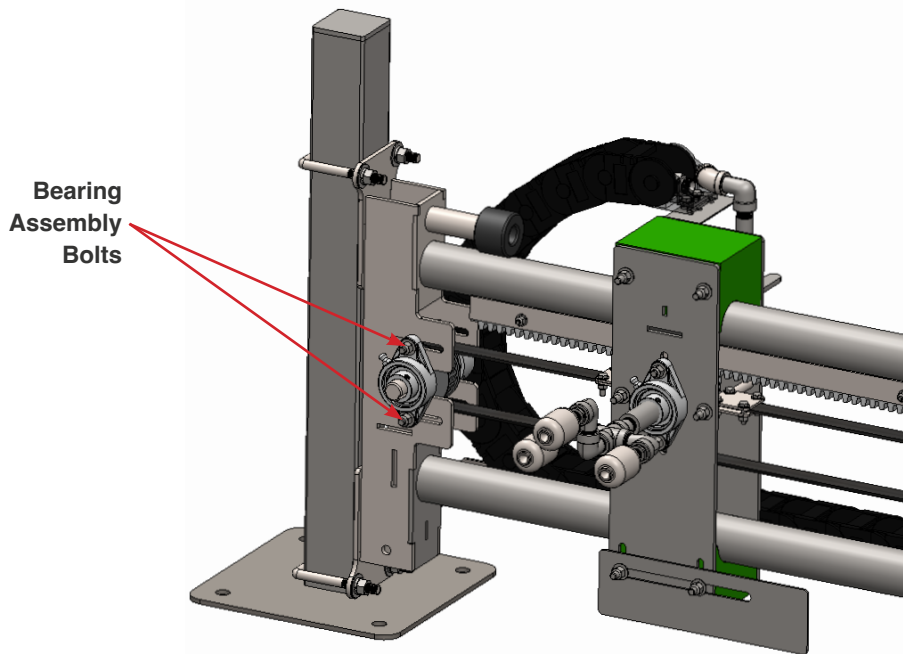

Fig. 7.2.7 - 1 - Belt bearing assembly bolt location

4. Disconnect the motor wires to avoid damaging the cable.
5. Remove the motor from the gearbox.
 - Unthread the 4 bolts along the flange of the gearbox (Fig. 7.2.7 - 2, following page).
 - Lift vertically and set aside the motor. Do not to hit or damage the output shaft of the motor.
6. Remove the 4 bolts holding the gearbox mounts to the main system frame (Fig. 7.2.7 - 2).

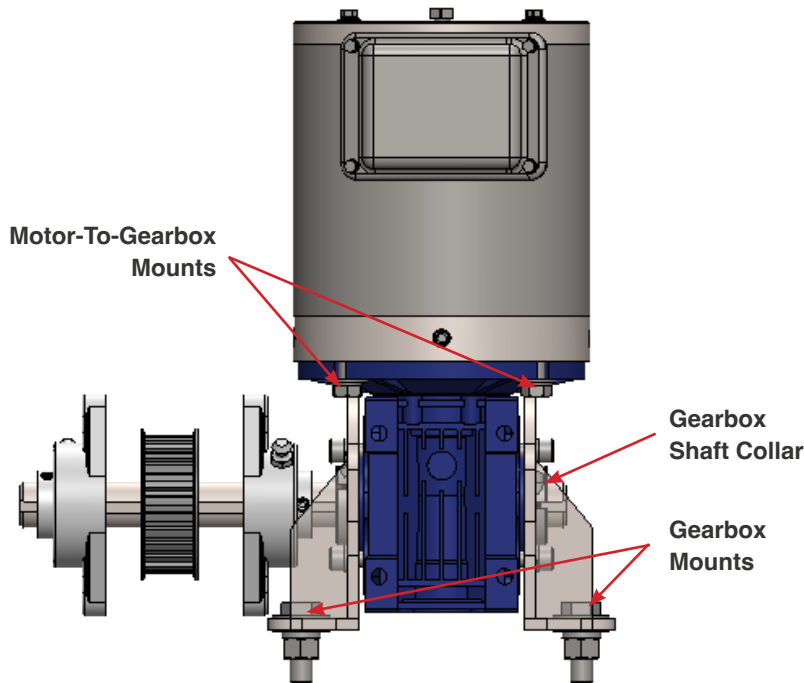
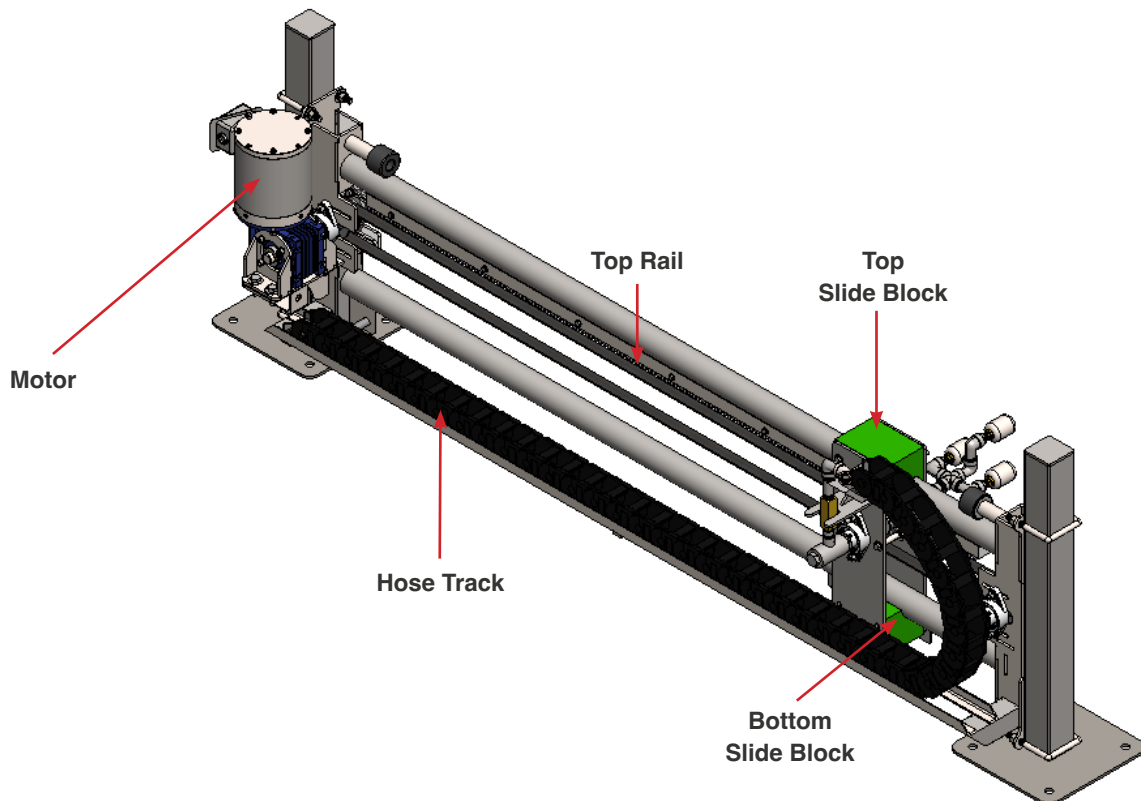
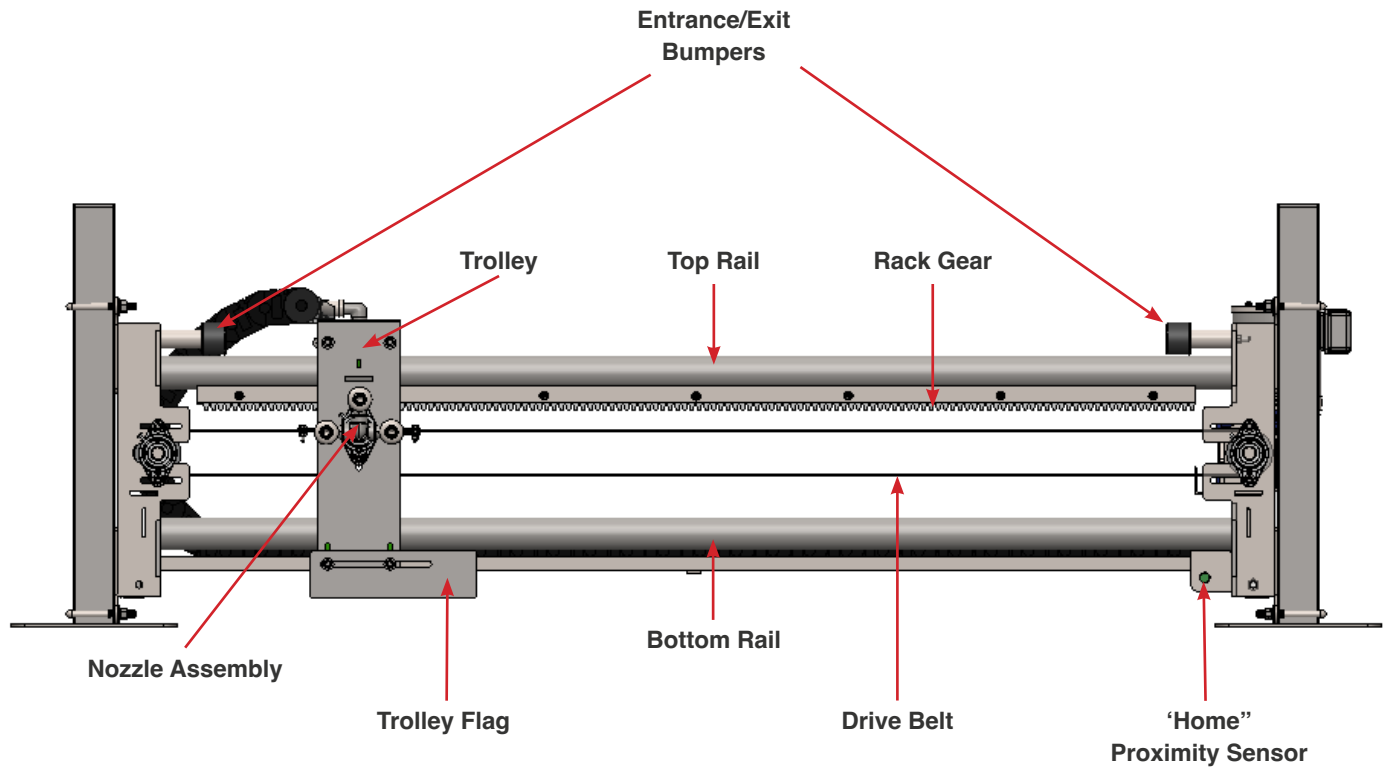
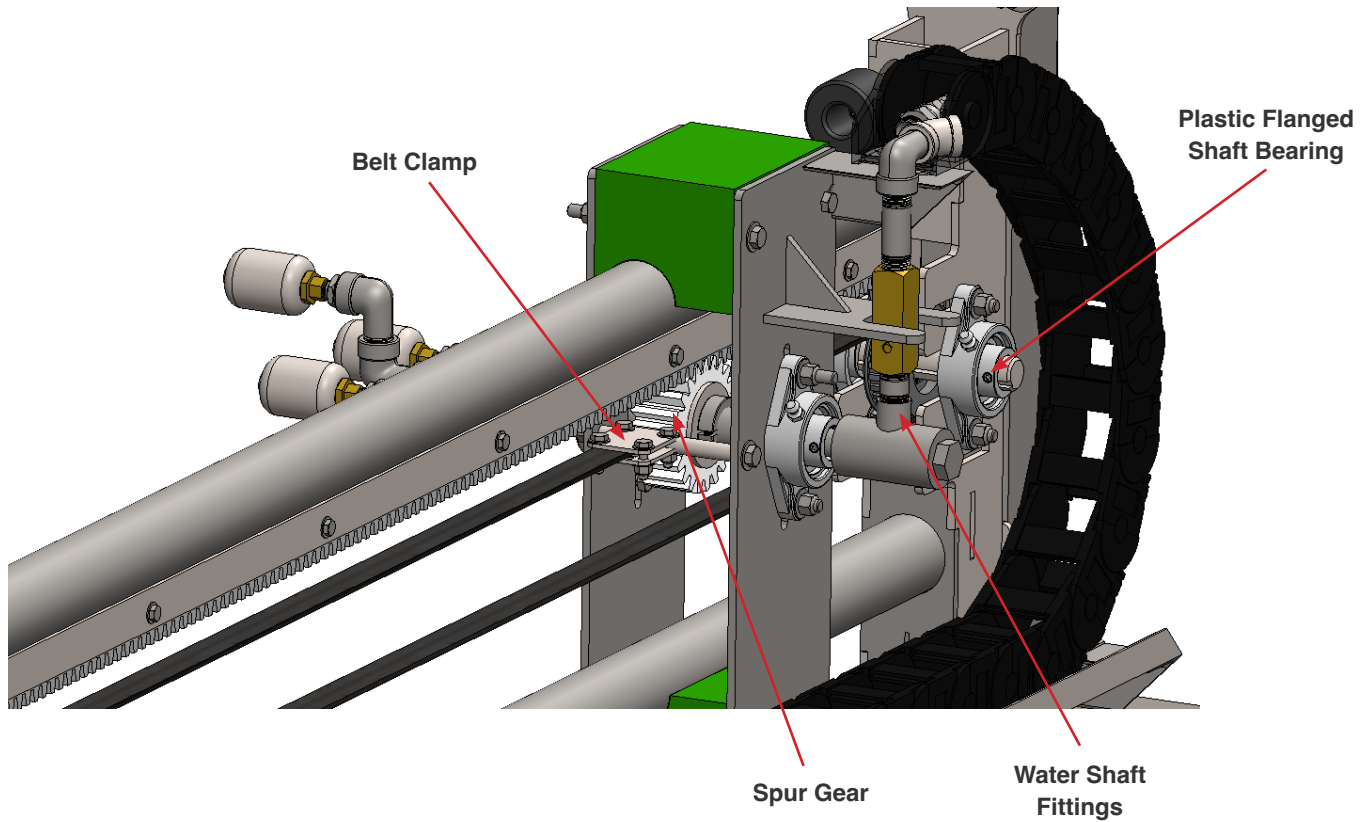
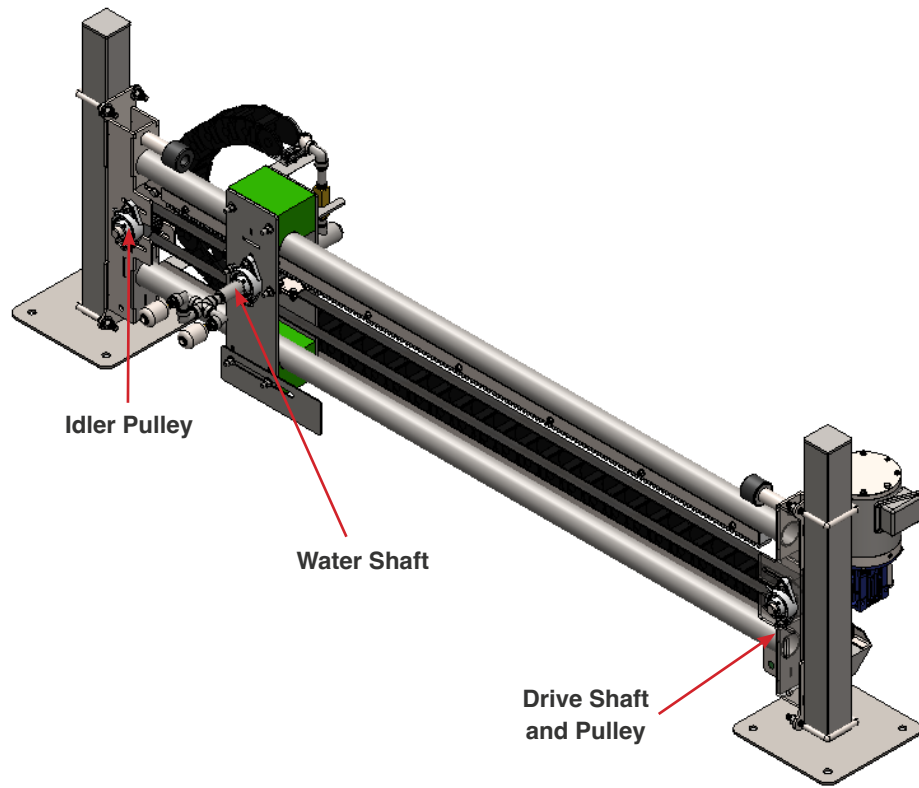

Fig. 7.2.7 - 2 - Belt bearing assembly bolt location

7. Loosen the shaft collar towards the wall and remove from the shaft.
8. Slide the gearbox off of the shaft.
 - There should be a piece of keystone that can be put aside for use upon installation of a new gearbox.
9. If using the same gear box:
 - Remove the gearbox mounts from the old gearbox and install onto the new gearbox in the same orientation.
10. If upgrading to a stainless steel gearbox:
 - Using the supplied hardware, install the new gearbox mounts onto the new gearbox in the same orientation as the old unit.
11. Slide the new gearbox back onto the shaft with the keystone installed.
 - Turning the input side of the gearbox will allow realignment of the keyway to the through hole on the gearbox.
 - Align to the mounting holes and reinstall the bolts.
12. Reinstall the shaft collar on back side of the shaft.
13. Reinstall the motor to the gearbox. Add additional antisieze if needed.
 - If using a stainless gearbox, ensure the new shaft adapter is used on the motor shaft going into the gearbox
14. Re-connect the motor wires.
15. Slide the bearings on and tighten the bolts holding the bearings.
16. Use a ruler or tape measure to check the belt deflection and follow the instructions in Appendix 3 - Parts & Service Notes to set the proper belt deflection (1.25").
17. Turn the Main Disconnect switch on the front of the electrical enclosure to the ON position (re-establish power to the wheelblastIT).

Appendix 1 - System Identification





Appendix 2 - Parts & Service Notes

Physical Parameters

Bottom Block to Bottom Rail: 3/32" Gap

A 3/32" gap is recommended between the bottom block and bottom rail for trolley stabilization. The bottom block stabilizes the trolley by minimizing tilting side to side and rocking back and forth. An unstable trolley is more likely to result in top or bottom blocks binding while sliding along the rails, spur gear jamming on the toothed rack, and increased belt wear.

- **Tools:** Two 9/16" wrenches, one 3/32" diameter probe longer than the bottom block, a hammer.

Adjusting Bottom Block Gap

Tools: Two 9/16" wrenches, one 3/32" diameter probe longer than the bottom block, a hammer.

NOTE

Adjusting the spur gear gap is much easier and quicker when the bottom block has the correct gap.

1. With two 9/16" wrenches, loosen the two nuts of the bottom block until block can be moved down with a gentle hammer tap.
2. Insert the probe at the lowest point between the bottom block and the bottom rail. The probe must extend past both ends of the block.
3. Raise the bottom block until snug against the probe at both ends. If tapping block up with a hammer, the tapping sound will change to a deeper tone when block is snug against the probe.
4. Tighten the 9/16" nuts while ensuring the block is snug against the probe at both ends of the block.
5. Remove the probe and, as a rule-of-thumb technique, see if the trolley flag looks level to confirm the bottom block is level.

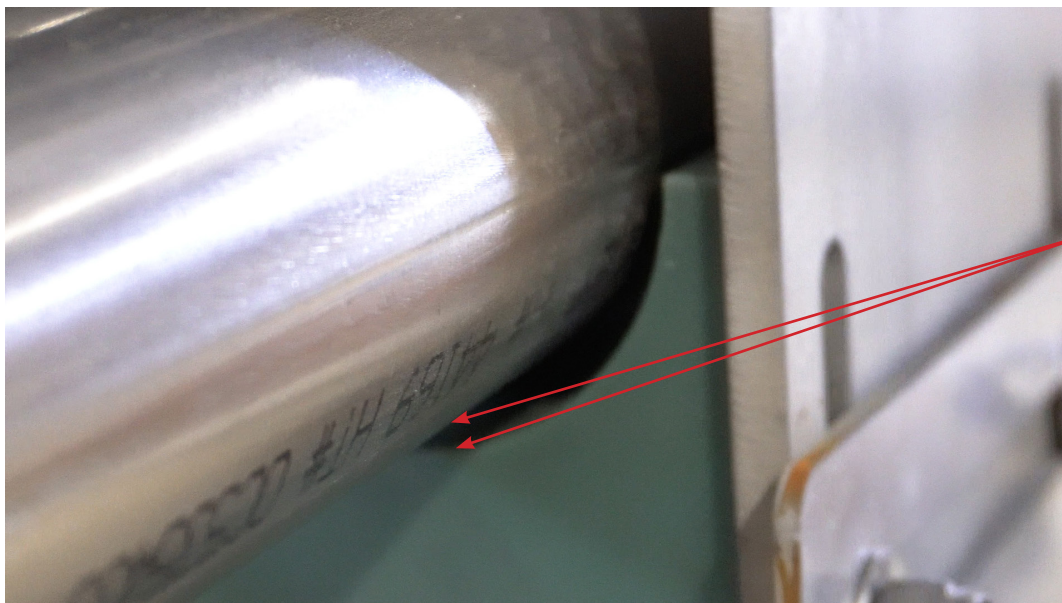

Fig. 1 - Bottom block to bottom rail gap

Spur Gear to Rack Gear: 3/32" Gap

The spur gear engages and turns the water shaft when the trolley moves forward to towards the exit bumper. The gap between the spur gear and rack gear must not be so tight as to add excess resistance to trolley movement but not so loose as to intermittently misalign gear teeth and block trolley movement.

Adjusting Spur Gear Gap

Tools: Two 9/16" wrenches, one 3/32" diameter probe with 1.5" of one end bent at a right angle.

NOTE

A correct gap of 3/32" between the bottom block and the bottom rail will help when adjusting the spur gear gap because, when lifting the spur gear, the entire trolley will be limited by the bottom block gap. Check this gap the entire length of travel.

1. Loosen the four nuts securing the two plastic flanged shaft bearing assemblies to the trolley side plates.
2. Lower the spur gear slightly and rest the short bent end of the 3/32" probe between the two uppermost teeth of the spur gear.
3. Lift spur gear until probe is held snug, pressed down by a tooth of the toothed rack.
4. Re-tighten the 9/16" nuts, leaving the probe end between the teeth.
5. Manually pull the trolley belts to roll over the probe a couple of times.
 - A correct gap is indicated by feeling the trolley gently "bumping" as it moves past the point where the probe-filled spur gear teeth meets the toothed rack.
 - Too small of a gap is indicated by a trolley difficult to pull past that point.
6. Remove probe and double check all four 9/16" nuts are secure.

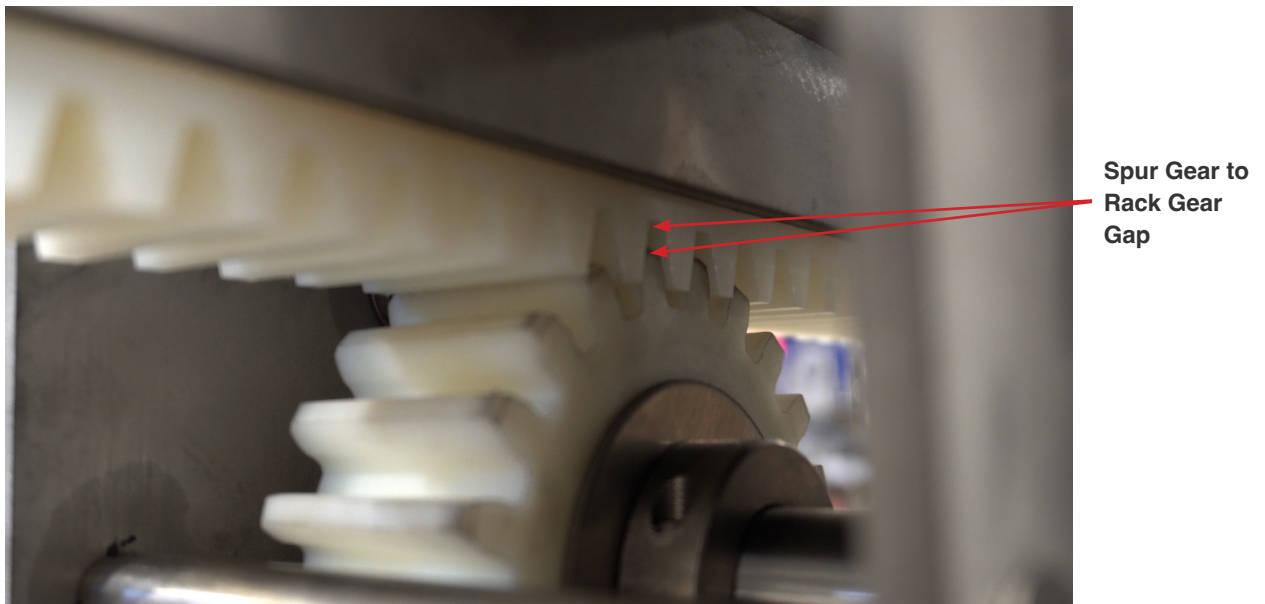

Fig. 2 - Spur gear to rack gear gap

Belt Deflection: 1.25"

A belt deflection of 1.25" is recommended. Belt tension is measured by the amount a belt deflects from a line drawn between the two uppermost or two lowermost locations where the belt is in contact with the pulleys.

Consistency in how belt deflection is measured is critical when the same or different repair personnel may work on the wheelblastIT at different times.

The belt turns around drive and idler pulleys to pull the trolley back and forth along the rails. If there is too much tension on the belt, the belt motor will need increased amperage to turn and a VFD may exceed the amperage safety limit. If the belt is too loose, the drive pulley may skip belt teeth, leading to variable trolley forward travel distances and poor cleaning performance.

Measuring Belt Deflection

Tools: Two 9/16" wrenches, ruler or tape measure, a hammer.

The following steps are recommended to ensure consistency, accuracy, and simplicity when measuring belt deflection:

1. Push the trolley past the 'Home' position to the bumper at the entrance side of the rails.
2. At the exit end of the rails, as close as possible to the idler pulley, measure the distance from the lowest point of the toothed rack to the top of the belt of the upper belt run.
3. Add 1.25" to that measurement.
4. At the mid-point between the idler pulley and the exit-side belt clamp, push down on the upper belt run until the lower belt run no longer rises up.
5. The tension applied by pushing down readies the upper belt run deflection measurement for the purpose of this procedure.
6. While maintaining downward tension on the upper belt run, at the mid-point between the idler pulley and the belt clamp, measure the distance from the lowest point of the rack gear to the top of the belt at the lowest point of the deflected upper belt run.
7. If this measured belt deflection is not within a quarter inch (0.25") of the measurement at the idler pulley plus 1.25", then belt tension adjustment is required.

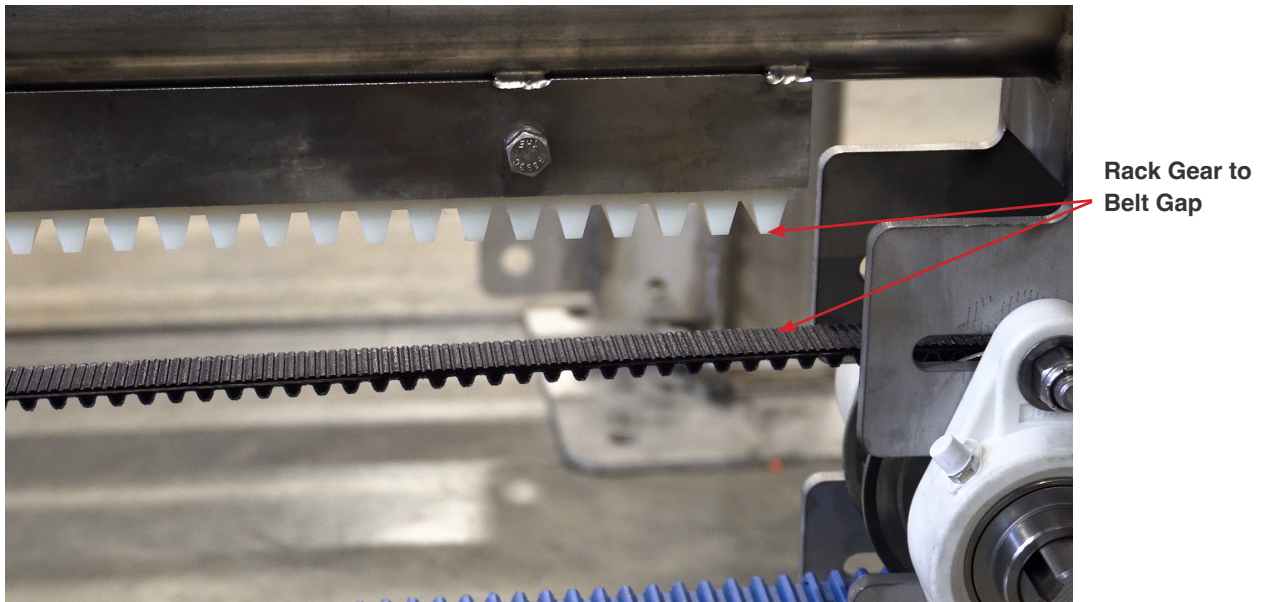

Fig. 3 - Rack gear to belt gap

Adjusting Belt Tension

1. At the idler pulley, loosen the four 9/16" nuts on the two plastic flanged shaft bearing assemblies only enough that a gentle hammer tap will move the bearing slightly.

2. Use the hammer to gently adjust the position of both bearing assemblies. Make sure the pulley shaft remains at a right angle (perpendicular) to the rails.
 - Small adjustments will result in a large change in the belt deflection measurement.
3. Remeasure the belt deflection and readjusting the position of the idler pulley shaft bearing assemblies, until the belt deflection is correct.
4. Tighten all four of the 9/16" nuts on the bearing assemblies. Be sure not to over-tighten bolts and bend trolley side plates in towards each other.

Home Proximity Sensor to Flag: 1/8" Gap Maximum

A sensor to flag gap of 1/8" is recommended. The 'Home' proximity sensor detects when the trolley flag is in front of the sensor barrel.

If the gap is too small, the stiff metal flag may hit the sensor and stop the trolley from returning to the Home position. If the gap is too large, the sensor may not detect the flag and the trolley will no longer move forward.

The maximum distance the sensor will detect the flag is about 1/4". However, at this distance, the trolley may be detected late in the reverse movement cycle and hit the entrance side bumper, ultimately resulting in inconsistent forward travel distances.

Measuring the Gap

Tools: Two 15/16" wrenches, possibly a 15/16" deep socket wrench, a 1/8" probe (can use 1/8" hex driver that is also used on plastic flanged shaft bearing set screws).

1. Move the trolley until the flag covers the entire face of the sensor. If the 1/8" probe fits in between sensor and flag without extra space, then the gap is set correctly.

Adjusting The Gap/Repositioning The Sensor

1. Reposition the sensor by moving the two jam nuts along the threaded barrel of the sensor.
2. Create space to work in by pushing the trolley away from the 'Home' position.
3. Unscrew the sensor cable from the back of the sensor to minimize chances of damaging the connection.
4. Secure the wall-side jam nut with a 15/16" wrench and loosen the car-side jam nut with the other 15/16" wrench.
5. With the jam nuts loose, turn the jam nuts up or down the sensor barrel until, when jam nuts are tightened, the face of the sensor is 1/8" from the flag when the trolley is in the 'Home' position.

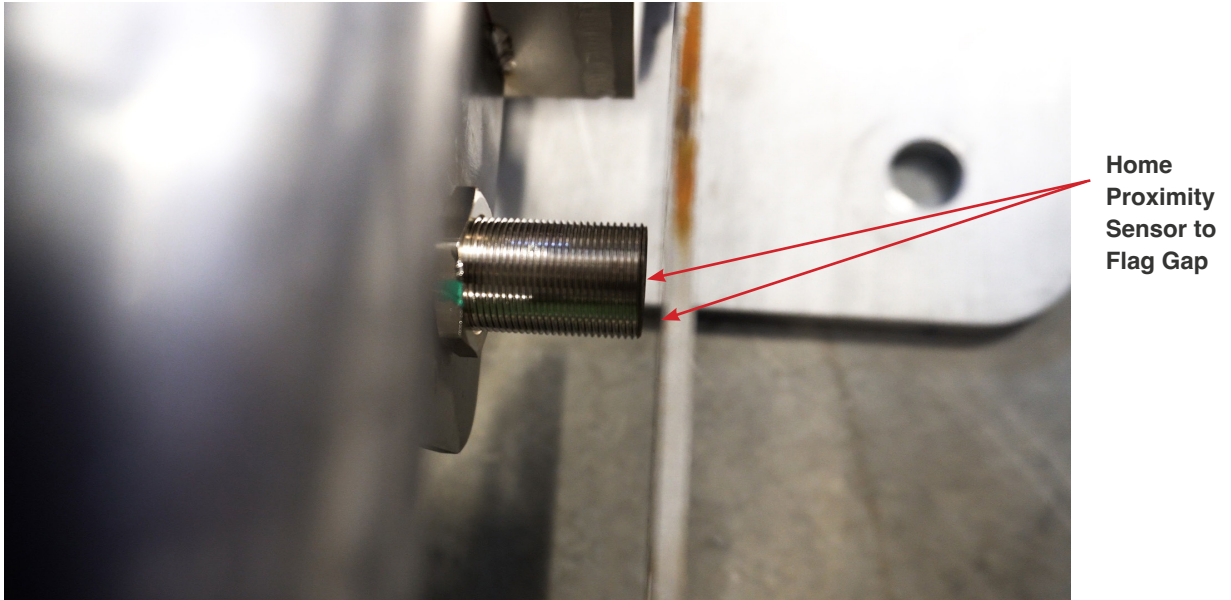

Fig. 4 - Home proximity sensor to trolley flag gap

Appendix 3 - HMI Screens

Main

Input/Output
Status Indicators

FT / MIN: 46
IN / SEC: 9

DRIVER SIDE PASS. SIDE

HOME PROX HOME PROX Proximity Switch Status Indicators

FWD FWD Forward Movement Indicators

REV REV Reverse Movement Indicators

FAULT FAULT Fault Indicators

AMPS 0.0 AMPS 0.0 Operating Amperage

SPEED 0 Hz SPEED 0 Hz Operating Speed

INPUTS

PULSE:

TIRE SWITCH:

TUNNEL TIRE SIGNAL:

CONVEYOR MONITOR:

COLLISION CONTROL:

OUTPUTS

WATER SOL:

Maintenance

Main Maintenance Settings

FT / MIN: 46
IN / SEC: 9

DRIVER SIDE PASS. SIDE

HOME PROX HOME PROX

FWD FWD

REV REV

FAULT FAULT

AMPS 0.0 AMPS 0.0

SPEED 0 Hz SPEED 0 Hz

ENABLE DS TROLLEY Use to remove DS Trolley from service

ENABLE PS TROLLEY Use to remove PS Trolley from service

FORCE TROLLEYS FORWARD Use to force both Trolleys forward

FORCE TROLLEYS REVERSE Use to force both Trolleys to reverse

WB TEST MOVE Use to test cycle both Trolleys forward and reverse

FORCE WB WATER Use to force both solenoid and pump on

Settings

Main	Maintenance	SETTINGS	FT / MIN:	46
			IN / SEC:	9
Conveyor Inches per Revolution		9		
Pulses per revolution		1		
Slower Speed Modification		4		
WB Starting Position		1		
Travel Distance		53 IN		



Appendix 4

Electrical Schematics

120v



Appendix 5

Electrical Schematics

24v